



105 Bonnie Drive
Butler, PA 16002
724-283-4681
724-283-5939 (fax)
www.bwieagle.com

PRODUCT INFORMATION BULLETIN

TWO-TIMER PLUS Dust Suppression System MODEL 60-9100

DESCRIPTION

The EAGLE® TWO-TIMER PLUS is an enhanced version of the original Two-Timer. A sensor input connector has been added to the left side of the control unit. A standard speed sensor (Model10-7003) should be attached to this input. This will allow the user to detect that the conveyor is running and eliminate the need to run a 120 VAC line back to the motor starter. The control unit can now be powered by any convenient 120 VAC source. Install the sensor on a conveyor roller or shaft (see sensor installation page). The operation of the TWO-TIMER PLUS is as follows: When the non-contacting sensor detects motion from the conveyor roller, a signal is sent to the control unit to start the "spray on" cycle. As long as the control unit is detecting ample pulses from the sensor (100 RPM or greater), the unit will continue to cycle the on and off times set by the user. If the conveyor roller slows down or stops, the TWO-TIMER PLUS will stop spraying and stay in the "spray off" cycle. When the conveyor re-starts and comes up to speed, the sensor will signal the control unit to turn on the sprays at the beginning of the "spray on" cycle. * A memory I.C. has been added to this model. If enabled (the default if OFF), the unit will "remember" the cycle and time left in the cycle when the conveyor stopped. For example; the conveyor stops six minutes into a twelve minute spray cycle. The spray automatically stops when the belt stops. When the belt restarts, spraying continues with the six minutes left in the cycle. This feature eliminates two problems: unnecessary wetting of the belt and flooding around the belt. To enable the memory feature, see "[SET-UP OPTIONS](#)".

SPECIFICATIONS

AC Input	120 VAC 20W
Fuse Protected	2 Amp
Operating Temperature	-40° to 60°C
AC Output	120 VAC 5 Amp MAX
On and Off Timers	1 - 60 Minutes, Adjustable
Memory (EEPROM)	On - Off (user selectable)
Minimum Sensing Speed	100 RPM (Factory Set)



CONTROLS AND INDICATORS

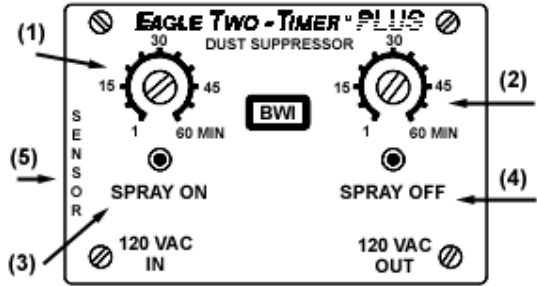

- 1) On Time Adjustment - Potentiometer used to adjust solenoid "on-time" from 1-60 minutes. (Note #1)
- 2) Off Time Adjustment - Potentiometer used to adjust solenoid "off-time" from 1-60 minutes. (Note #1)
- 3) Spray On LED - When illuminated, indicates unit is in the 'spray-on' cycle.
- 4) Spray Off LED - When illuminated, indicates unit is in the 'spray-off' cycle.
- 5) Sensor Input Connector - Attach EAGLE VARIABLE RELUCTANCE SENSOR to this connector and install on conveyor roller (See sensor installation sheet)

Note #1 - Any adjustments of the potentiometers for both the "on" and "off" timers will not take effect until the cycle the unit is currently in completes.

TWO-TIMER PLUS

Dust Suppression System

MODEL 60-9100

SET-UP OPTIONS

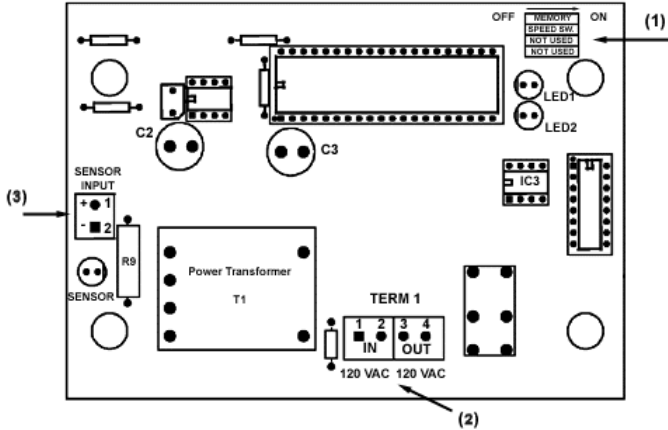

1) **SW1-1 Memory Select Switch** - Enables or disables the memory when the sensor has detected that the conveyor has stopped or AC power is lost. The default setting for this switch is "OFF". To change this option, do the following:

- A) Locate the 4-position DIP switch in the upper right section of the PC Board (#1)
- B) The top switch (SW1-1) should be in the "OFF" position (rocker switch pushed towards the left) To enable the memory, push this rocker switch towards the "right" to the on position. (A ball point pen or small screwdriver should be used to move the switch)

SW1-2 Speed Switch - Enables or disables the sensor input signal. The default setting for this switch is "ON". To change this option, do the following:

- A) Locate the 4-position DIP switch in the upper right section of the PC Board. (#1)
- B) The second switch position (SW1-2) should be in the "ON" position. (rocker switch pushed toward the right). To disable the sensor control signal, push the rocker switch towards the "left" to the "OPEN/OFF" position. **NOTE** - By turning this switch to the "OFF" position, a sensor is no longer required for operation. However, for proper operation in this mode, the 120VAC input must now be connected to a "switched 120VAC" source back at the motor starter. (The Two-Timer will now operate like the model [60-9000!](#))

NOTE - Once AC power is applied to the unit, it will "read" the new switch settings

2) **120VAC In/Out Terminals** - Connect 120VAC input to terminals 1&2. Connect 120VAC output to solenoid on terminals 3&4.

3) **Sensor Input Terminals** - Connects the sensor input from the enclosure to the PC Board.

DIMENSIONS

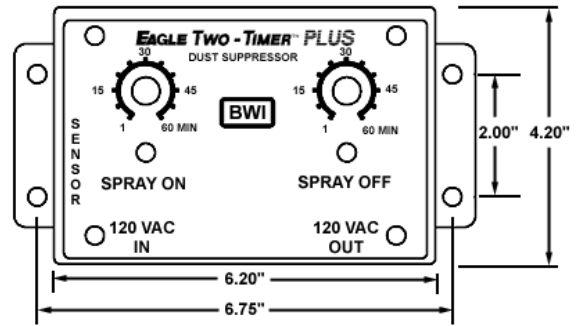

HARDWARE SPECIFICATIONS

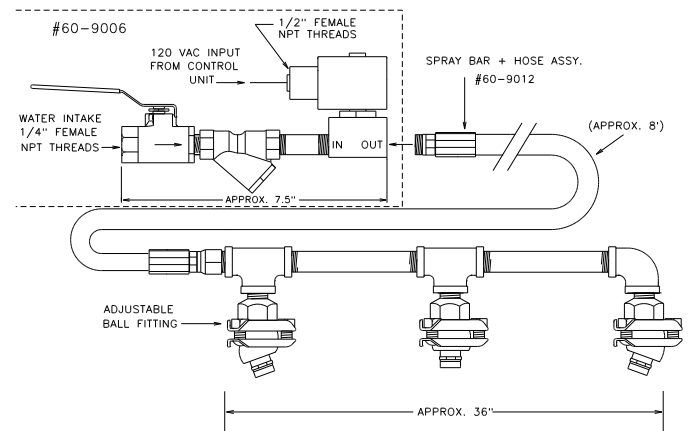

AC Input	120 VAC 6W
Maximum Water Pressure	500 P.S.I.
Minimum Water Pressure	5 P.S.I.
Maximum Water Temperature	180 Degrees Fahrenheit
Gallons Per Minute @ 400 P.S.I.	1.9 GPM

REPLACEMENT AND OPTIONAL PARTS

Control Unit	60-9105
Solenoid Valve Assembly	60-SOL-500
Spray Bar & Hose Assembly	60-SPRAY

DOCUMENT DATE: 6/5/14



105 Bonnie Drive
Butler, PA 16002
(724) 283-4681
Fax (724) 283-5939
www.bwieagle.com