



105 Bonnie Drive  
Butler, PA 16002  
724-283-4681  
724-283-5939 (fax)  
www.bwieagle.com

# PRODUCT INFORMATION BULLETIN

## AIR-EAGLE® XLT PLUS REMOTE STOP SWITCH 900 MHz RF Receiver MODEL 497-5280-AC

### DESCRIPTION

The AIR-EAGLE XLT PLUS PLUS Rx is an RF receiver designed to communicate with the AIR-EAGLE XLT PLUS TX in applications where a wireless stop switch is required. Integral high current relays can be directly interfaced with the customer's equipment. This unit will receive remote signals transmitted from ¼ mile or more. Our 900 MHz receiver has the capability of simultaneously networking with up to 8 transmitters in the direct vicinity. This model includes one dedicated log-in relay for each transmitter log-in confirmation. The auto-scan feature "locks" the unit onto a clear frequency without user intervention. Incorporating spread-spectrum technology, this model provides the utmost security and reliability. The full-duplex communication capability allows for a maintained fail-safe communications link while on board LEDs provide visual indication that communication is established and sustained.

### INSTALLATION

DISCONNECT AC Power from all equipment before installation.

1. Mount the AIR-EAGLE XLT PLUS RF RECEIVER where convenient to the motor control relay system.
2. Attach coax cable from external high gain antenna to the TNC connector on right side of receiver.
3. Connect AC power to the proper terminals in your control circuit.

### DIMENSIONS

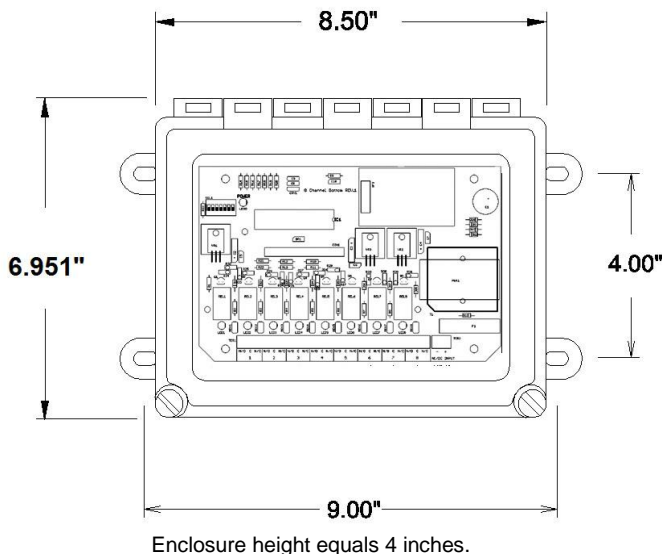

### TERMINAL STRIP WIRING

BOTTOM BOARD					
1	N/O Relay #1	10	N/O Relay #4	19	N/O Relay #7
2	C Relay #1	11	C Relay #4	20	C Relay #7
3	N/C Relay #1	12	N/C Relay #4	21	N/C Relay #7
4	N/O Relay #2	13	N/O Relay #5	22	N/O Relay #8
5	C Relay #2	14	C Relay #5	23	C Relay #8
6	N/C Relay #2	15	N/C Relay #5	24	N/C Relay #8
7	N/O Relay #3	16	N/O Relay #6		
8	C Relay #3	17	C Relay #6		
9	N/C Relay #3	18	N/C Relay #6		

Note #1 – Relays #1 thru 8 utilize a fail-safe relay configuration. The relay contacts are shown above in their de-energized state. Ex: The normally open contacts would be **closed** during normal operation. All relays energize at power-up.

AC INPUT	
Terminal #1	120VAC - Neutral
Terminal #2	120VAC - Hot

TOP BOARD					
1	N/O Relay #9	10	N/O Relay #12	19	N/O Relay #15
2	C Relay #9	11	C Relay #12	20	C Relay #15
3	N/C Relay #9	12	N/C Relay #12	21	N/C Relay #15
4	N/O Relay #10	13	N/O Relay #13	22	N/O Relay #16
5	C Relay #10	14	C Relay #13	23	C Relay #16
6	N/C Relay #10	15	N/C Relay #13	24	N/C Relay #16
7	N/O Relay #11	16	N/O Relay #14		
8	C Relay #11	17	C Relay #14		
9	N/C Relay #11	18	N/C Relay #14		

# AIR-EAGLE® XLT PLUS

REMOTE STOP SWITCH  
RF Receiver

**MODEL 497-5280-AC**

## CONTROLS AND INDICATORS

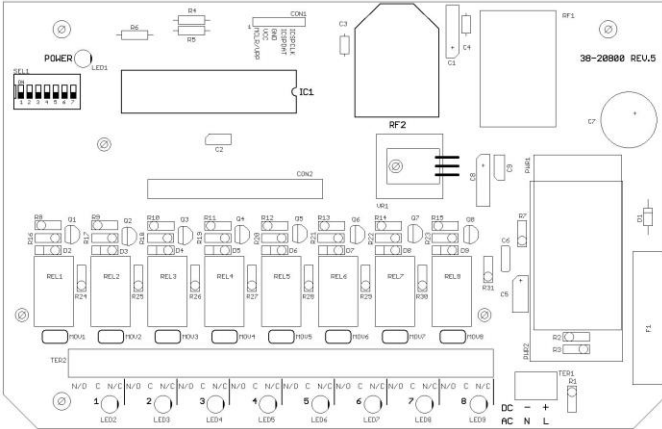

PWR LED	LED indicator of power status
RF2 (Receiver Module)	RF module that receives data from the remote transmitter(s)
RELAYS	16 SPDT output control relays
Relay LEDs	16 LED's indicating relay status
SEL1	7 Position Dip Switch for Selecting Receiver Number

## GENERAL OPERATION

When the unit is installed and electric power is applied, relays #1 thru #8 will energize. Transmitters log-into the system on their designated relay channel as they enter the work area. (see table below)

The transmitter and receiver(s) remain linked the entire time the operator is in the work zone. Should an emergency occur, the operator can press the STOP actuator to initiate the shut-down process and alert emergency personnel. Should the operator fail to hit the STOP button, the loss of RF link that would occur will also initiate the shut-down process. As such, the operator must remember to log-out of the system as they are leaving the work zone to avoid nuisance shut-downs. The shut-down relay will open when the STOP button is pressed. Both the Log-in and Shut-down relays will open when signal is lost from the dozer.

TRANSMITTER 'S CHANNEL AS SET-UP DURING INSTALLATION:	DESIGNATED SHUT-DOWN RELAY	DESIGNATED LOG-IN RELAY
Channel 1	1	9
Channel 2	2	10
Channel 3	3	11
Channel 4	4	12
Channel 5	5	13
Channel 6	6	14
Channel 7	7	15
Channel 8	8	16

## RECEIVER SELECTION

The receiver can be set up as RX 1 or RX 2 if using two receivers because there is a "Raw Coal" or "Clean Coal" pile. If using a repeater make sure it is set to the same "base" receiver number

DIP SWITCH SETTING (SEL1)		
Note – Switch 1 is the only active switch on this model. No changes should be made to switches 2 thru 7		
Receiver Number	SW1	SW2 thru SW7
1 (default)	Open	Not Used
2	Closed	

## SPECIFICATIONS

Power Supply	120VAC 50/60 Hz, 5W
Fuse Protected	1 amp
Transceiver Frequency	900 MHz Spread Spectrum
Receiver Range	Approximately 1 mile (up to 10 miles with external antennas - see accessories)
Enclosure	Hinged fiberglass with window / NEMA 4, 12 + 13

## REPLACEMENT PARTS & ACCESSORIES

PC Board (Main)	497-5282-AC
Air-Eagle XLT PLUS TX	497-5100-CHx
Replacement Antennas:	
Medium Range Operation - External (Greater than 2/3 mile / Less than 2 miles) *	49-3101
Long Range Operation - External (Greater than 2 miles / Up to 10 miles) *	49-3102
* = Line of Sight	

## APPROVALS

United States (FCC)	MCQ-XBPSX
Canada (IC)	1846A-XBPSX

## LIMITED WARRANTY STATEMENT

BWI Eagle Inc. warrants the Air-Eagle Remote Control System, if properly used and installed, will be free from defects in material and workmanship for a period of 1 year after date of purchase. Said warranty to include the repair or replacement of defective equipment. This warranty does not cover damage due to external causes, including accident, problems with electrical power, usage not in accordance with product instructions, misuse, neglect, alteration, repair, improper installation, or improper testing. This limited warranty, and any implied warranties that may exist under state law, apply only to the original purchaser of the equipment, and last only for as long as such purchaser continues to own the equipment. This warranty replaces all other warranties, express or implied including, but not limited to, the implied warranties or merchantability and fitness for a particular purpose. BWI Eagle makes no express warranties beyond those stated here. BWI disclaims without limitation, implied warranties of merchantability and fitness for a particular purpose. Some jurisdictions do not allow the exclusion of implied warranties so this limitation may not apply to you. To obtain warranty service, contact BWI Eagle for a return material authorization. When returning equipment to BWI Eagle, the customer assumes the risk of damage or loss during shipping and is responsible for the shipping costs incurred.

# AIR-EAGLE® XLT PLUS

REMOTE STOP SWITCH  
RF Receiver

MODEL 497-5280-AC

## RELAY WIRING

All relays are dry contact. The bottom board (stop) relays turn on at power up and are wired in series so if any unit hits the E-stop button, or loses link, the control connection will open.

When a unit logs in, its corresponding **login relay** (top board) will turn on.

At this point, if its E-stop button is pressed, its **stop relay** on the bottom board will turn off. If the unit logs out, then its **login relay** will turn off, but its **stop relay** will remain on.

If the link to the unit is lost while logged in, then both the **stop relay** and **login relay** will turn off.

### 497-5280 - Top Board - Login Relays

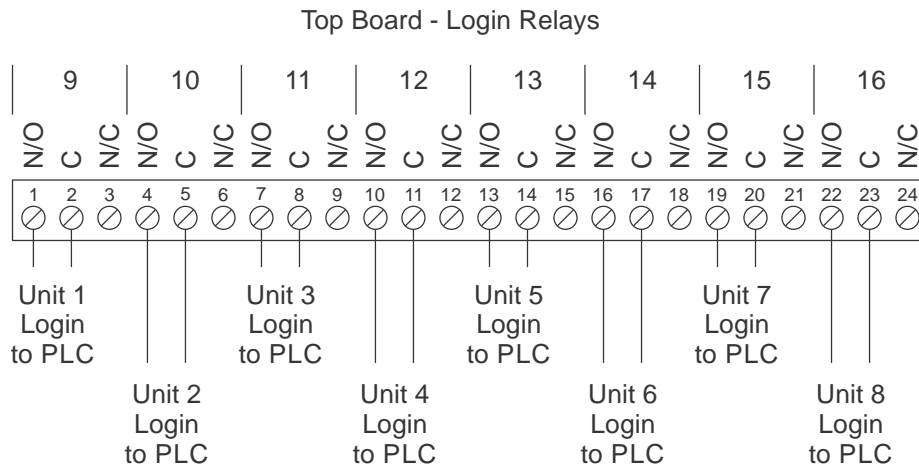

### 497-5280 - Bottom Board - Stop Relays

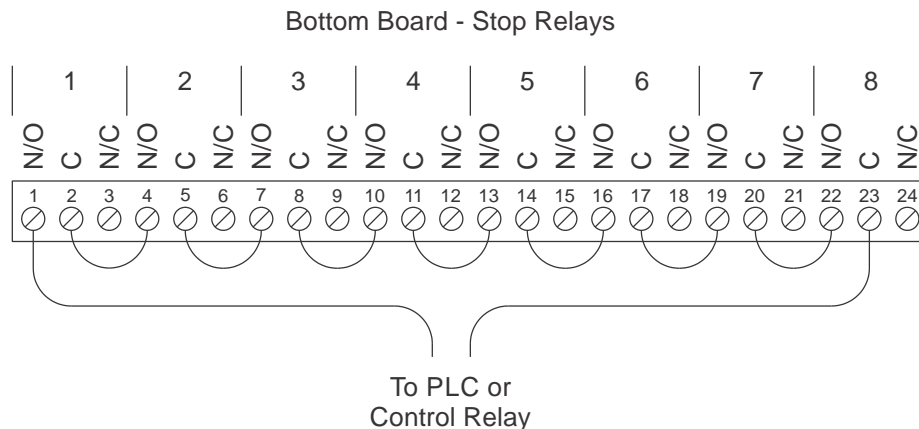

# AIR-EAGLE® XLT PLUS

REMOTE STOP SWITCH  
RF Receiver

**MODEL 497-5280-AC**

## RELAY LOGIC

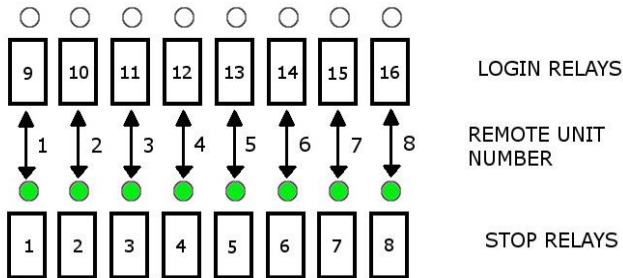

Each remote unit uses a pair of relays to show its state.

The top board relays show the login state of its remote unit.

The bottom board relays are on at power up. Each bottom relay represents the stop condition of its remote unit. If the remote unit stop button is pressed or loses link, its stop relay will turn off.

When the remotes stop button is released its stop relay will turn back on

### Examples for Remote #1

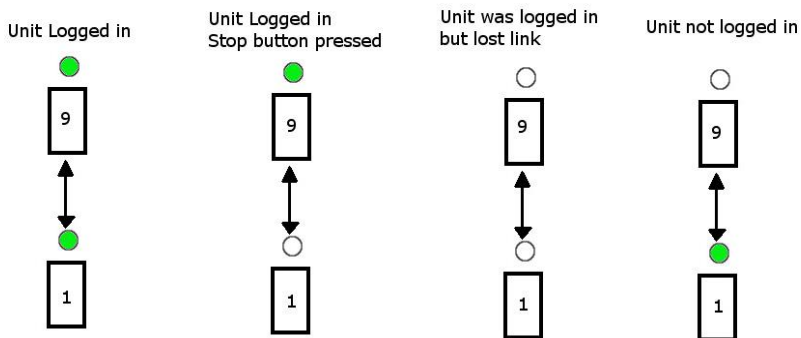

DOCUMENT DATE: 04/09/19 / PRODUCT REV. 3



105 Bonnie Drive  
Butler, PA 16002  
(724) 283-4681  
Fax (724) 283-5939  
[www.bwieagle.com](http://www.bwieagle.com)

# Air-Eagle XLT Plus, Dozer Stop Switch System Installation Notes

## Dozer E-Stop Placement

### Dozer components:

- 1) Dozer stop switch transmitter (Model 497-5100-CHx-DC)
- 2) Magnetic roof-mount antenna (Model 49-2102)

The transmitter should be located in the cab of the vehicle, mount so the operator can see the visual status LED's and be able to reach and depress the STOP SWITCH if needed.

A two-conductor cable is supplied to power the dozer transmitter. The black lead is always negative.

Depending on the cable/ plug supplied, the white wire (or red) will go directly to the vehicle battery power. The voltage range is 9VDC up to 36VDC.

If using, connect tilt switch inputs to the proper terminals on the input terminal strip.

Next, mount the magnetic roof-mount antenna on the roof of the dozer. Always try to find a location as far as possible (at least 3 feet) from any other antennas that may be on the roof of the dozer. Feed the cable into the cab of the dozer and attach by screwing the "TNC" connector to the "RF" connector on the right side of the transmitter.

## Receiver & Optional Repeater Placement – See Placement Per Your Configuration Below:

**Configuration #1** - If your PLC I/O controls are located at the stock pile, the receiver is to be mounted there on the stacking tubes.

### Receiver components:

- 1) 16 Relay receiver in NEMA 4 enclosure (Model # 497-5280)
- 2) TNC "T" adapter (Model 49-5001)
- 3) Two Coax cables with connectors (Model 49-4000-XX)
- 4) Two Omni directional antennas with mounting hardware (Model 49-3101)

Locate a 120VAC source for powering the receiver.

Mount two omni antennas on the rail or floor of the cat walk. It is recommended to have the antennas mounted on opposite corners of the cat walk, pointing "down", below the cat walk floor, at the dozer stock pile to get a good 360 degree reception pattern around the stacking tube(s).

Attach coax cables to each antenna then connect to the receiver via the "T" adapter which connects to the TNC antenna connector on the side of the receiver.

**Configuration #2** - If your PLC I/O controls are located in a separate control room, a repeater is to be mounted at the stock pile and the receiver is to be located at the control room

**Repeater components:**

- 1) Repeater in NEMA 4 enclosure (Model 497-4500-120VAC)
- 2) TNC "T" adapter, (Model 49-5001)
- 3) Two Coax cables with connectors (Model 49-4000-XX)
- 4) Two Omni directional antennas with mounting hardware (Model 49-3101)

Locate a 120VAC source for powering the repeater.

Mount two omni antennas on the rail or floor of the cat walk. It is recommended to have the antennas mounted on opposite corners of the cat walk, pointing "down", below the cat walk floor, at the dozer stock pile to get a good 360 degree reception pattern around the stacking tube(s).

Attach coax cables to each antenna then connect to the repeater via the "T" adapter which connects to the TNC antenna connector on the side of the repeater.

**Receiver components:**

- 1) 16 relay receiver in a NEMA 4 enclosure (Model # 497-5280)
- 2) Coax cable with connectors (Model 49-4000-XX)
- 3) Omni directional antenna with mounting hardware (Model 49-3101)

The receiver is recommended to be located at the PLC I/O cabinet in the control room.

Locate a 120VAC power source for this receiver.

Mount the omni antenna on the outside of the plant, as high as possible so the antenna can "see" the antenna from the repeater located at the stacker tube for maximum performance and range.

Attach coax cable to the antenna then connect to the TNC antenna connector on the side of the receiver.

Install control wiring from the relays in the receiver to the belt feeder control circuits. See product information bulletin for relay output logic.