



105 Bonnie Drive
Butler, PA 16002
724-283-4681
724-283-5939 (fax)
www.bwieagle.com

PRODUCT INFORMATION BULLETIN

AIR-EAGLE® XLT PLUS High Power 900MHz RF Repeater MODEL 497-4500-AC

DESCRIPTION

The AIR-EAGLE XLT PLUS RF REPEATER IS designed to retransmit an RF signal from any Air-Eagle XLT PLUS Transmitter. When placed in an area where the signal is weak, this unit will then re-transmit at full strength facilitating greater distances and allowing the RF signal to reach around corners, through tunnels, over hills and through valleys.

APPROVALS

United States (FCC)	MCQ-XBPSX
Canada (IC)	1846A-XBPSX

INSTALLATION

DISCONNECT AC Power from all equipment before installation.

1. Mount the AIR-EAGLE XLT PLUS RF REPEATER as high as possible above the stock pile where the work is being performed.
2. Mount the external antennas on opposite sides of the catwalk, pointing downward. Connect "T" adapter to the TNC connector on the side of the receiver. Attached coax cables to base of antennas and run down to connect to the "T" adapter.
3. Plug supplied AC wall plug adapter into 110VAC outlet.

TERMINAL STRIP WIRING

TERMINAL STRIP WIRING (TER1)	
Terminal 1	120VAC Neutral
Terminal 2	120VAC Hot
Terminal 3	Not Used
Terminal 4	Not Used
Terminal 5	Not Used
Terminal 6	Not Used
Terminal 7	Not Used
Terminal 8	Not Used
Terminal 9	Not Used
Terminal 10	Not Used
Terminal 11	Not Used
Terminal 12	Not Used
Terminal 13	Not Used
Terminal 14	Not Used
Terminal 15	Not Used
Terminal 16	Not Used
Terminal 17	Not Used
Terminal 18	Not Used



CONTROLS & INDICATORS

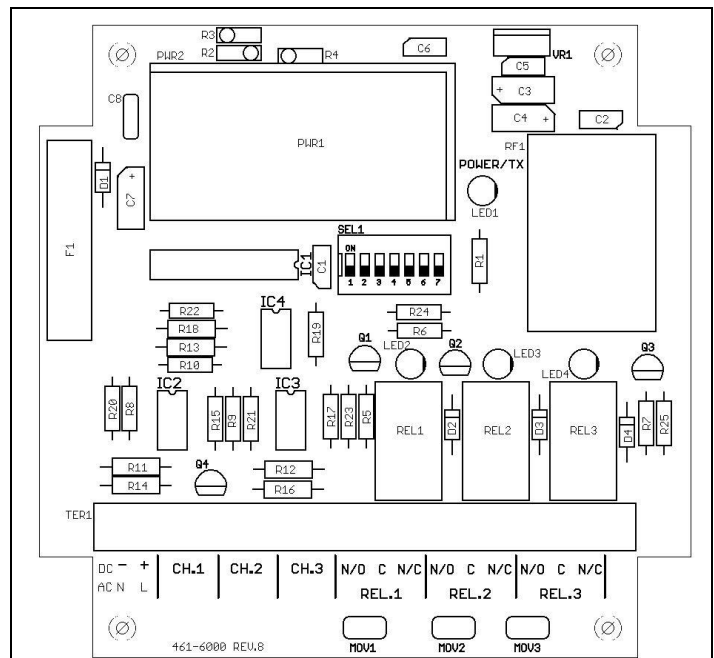

RX LED	Yellow LED illuminates when linked with the Base receiver
POWER LED	Green LED is illuminated while power is applied to the repeater
TX LED	Red LED illuminates when linked with the Base receiver
RF1	RF module that receives data from the remote transmitter
SEL1	Used to set System number

AIR-EAGLE® XLT PLUS

High Power 900MHz RF Repeater

MODEL 497-4500-AC

BASE RECEIVER SET-UP

This unit is shipped from the factory with SEL1 switches in the open positions and is operating with Receiver #1. If you wish to change the default Receiver #, follow the instructions below:

- 1) Remove power from unit
- 2) Remove top cover.
- 3) Select desired base receiver #.
- 4) Reattach cover and apply power.
- 5) Programming is now complete.

BASE RECEIVER SELECTION

	OFF(Default)	ON
SEL 1 (SW1)	RECEIVER #1	RECEIVER #2
SEL1 (SW2-7)	Not used on this model	

DIMENSIONS

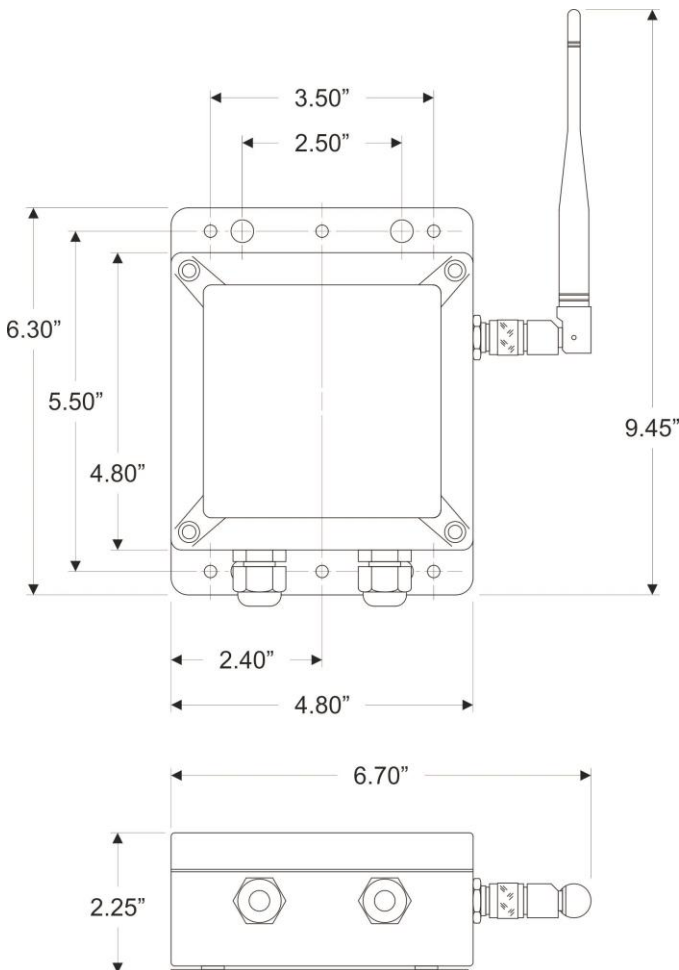

SPECIFICATIONS

Power Supply	120VAC 50/60Hz 5W Max
Fuse Protected	2 amp
Frequency	900MHz Spread Spectrum
RF Channels	Seven independent network frequencies
RF Output Power	1W
Transmit Range	Approximately 1 Mile (Up to 10 miles with external antenna - see accessories)
Transmitter Data	Repeater
Enclosure	Polycarbonate, IP66 (NEMA 4)
Operating Temp	-40° F - +185° F

REPLACEMENT PARTS & ACCESSORIES

PC Board (Main)	497-4502-AC
Standard Antenna (Included):	
900MHz Portable Antenna (For distances up to 1 Mile*)	49-1103
Optional Antennas and Accessories:	
900MHz Omni Directional Antenna	49-3101
900MHz 13dB Yagi Antenna	49-3102
Flex Coax Cable w/Connectors	49-4000-XX (XX = # of Feet)
* = Line of Sight	

LIMITED WARRANTY STATEMENT

BWI Eagle Inc. warrants the Air-Eagle Remote Control System, if properly used and installed, will be free from defects in material and workmanship for a period of **1 year** after date of purchase. Said warranty to include the repair or replacement of defective equipment. This warranty does not cover damage due to external causes, including accident, problems with electrical power, usage not in accordance with product instructions, misuse, neglect, alteration, repair, improper installation, or improper testing. This limited warranty, and any implied warranties that may exist under state law, apply only to the original purchaser of the equipment, and last only for as long as such purchaser continues to own the equipment. This warranty replaces all other warranties, express or implied including, but not limited to, the implied warranties or merchantability and fitness for a particular purpose. BWI Eagle makes no express warranties beyond those stated here. BWI disclaims without limitation, implied warranties of merchantability and fitness for a particular purpose. Some jurisdictions do not allow the exclusion of implied warranties so this limitation may not apply to you. To obtain warranty service, contact BWI Eagle for a return material authorization. When returning equipment to BWI Eagle, the customer assumes the risk of damage or loss during shipping and is responsible for the shipping costs incurred.

DOCUMENT DATE: 4/17/19 / PRODUCT REV.6



105 Bonnie Drive
Butler, PA 16002
(724) 283-4681
Fax (724) 283-5939
www.bwieagle.com

Air-Eagle XLT Plus, Dozer Stop Switch System Installation Notes

Dozer E-Stop Placement

Dozer components:

- 1) Dozer stop switch transmitter (Model 497-5100-CHx-DC)
- 2) Magnetic roof-mount antenna (Model 49-2102)

The transmitter should be located in the cab of the vehicle, mount so the operator can see the visual status LED's and be able to reach and depress the STOP SWITCH if needed.

A two conductor cable is supplied to power the dozer transmitter. The black lead is always negative.

Depending on the cable/ plug supplied, the white wire (or red) will go directly to the vehicle battery power. The voltage range is 9VDC up to 36VDC.

If using, connect tilt switch inputs to the proper terminals on the input terminal strip.

Next, mount the magnetic roof-mount antenna on the roof of the dozer. Always try to find a location as far as possible (at least 3 feet) from any other antennas that may be on the roof of the dozer. Feed the cable into the cab of the dozer and attach by screwing the "TNC" connector to the "RF" connector on the right side of the transmitter.

Receiver & Optional Repeater Placement – See Placement Per Your Configuration Below:

Configuration #1 - If your PLC I/O controls are located at the stock pile, the receiver is to be mounted there on the stacking tubes.

Receiver components:

- 1) 16 Relay receiver in NEMA 4 enclosure (Model # 497-5280)
- 2) TNC "T" adapter (Model 49-5001)
- 3) Two Coax cables with connectors (Model 49-4000-XX)
- 4) Two Omni directional antennas with mounting hardware (Model 49-3101)

Locate a 120VAC source for powering the receiver.

Mount two omni antennas on the rail or floor of the cat walk. It is recommended to have the antennas mounted on opposite corners of the cat walk, pointing "down", below the cat walk floor, at the dozer stock pile to get a good 360 degree reception pattern around the stacking tube(s).

Attach coax cables to each antenna then connect to the receiver via the "T" adapter which connects to the TNC antenna connector on the side of the receiver.

Configuration #2 - If your PLC I/O controls are located in a separate control room, a repeater is to be mounted at the stock pile and the receiver is to be located at the control room

Repeater components:

- 1) Repeater in NEMA 4 enclosure (Model 497-4500-120VAC)
- 2) TNC "T" adapter, (Model 49-5001)
- 3) Two Coax cables with connectors (Model 49-4000-XX)
- 4) Two Omni directional antennas with mounting hardware (Model 49-3101)

Locate a 120VAC source for powering the repeater.

Mount two omni antennas on the rail or floor of the cat walk. It is recommended to have the antennas mounted on opposite corners of the cat walk, pointing "down", below the cat walk floor, at the dozer stock pile to get a good 360 degree reception pattern around the stacking tube(s).

Attach coax cables to each antenna then connect to the repeater via the "T" adapter which connects to the TNC antenna connector on the side of the repeater.

Receiver components:

- 1) 16 relay receiver in a NEMA 4 enclosure (Model # 497-5280)
- 2) Coax cable with connectors (Model 49-4000-XX)
- 3) Omni directional antenna with mounting hardware (Model 49-3101)

The receiver is recommended to be located at the PLC I/O cabinet in the control room.

Locate a 120VAC power source for this receiver.

Mount the omni antenna on the outside of the plant, as high as possible so the antenna can "see" the antenna from the repeater located at the stacker tube for maximum performance and range.

Attach coax cable to the antenna then connect to the TNC antenna connector on the side of the receiver.

Install control wiring from the relays in the receiver to the belt feeder control circuits. See product information bulletin for relay output logic.