



105 Bonnie Drive  
Butler, PA 16002  
724-283-4681  
724-283-5939 (fax)  
www.bwieagle.com

# PRODUCT INFORMATION BULLETIN

## AIR-EAGLE® XLT PLUS High Power 900MHz RF Receiver MODEL 461-8000-VBR-DC

### DESCRIPTION

The AIR-EAGLE XLT PLUS is an RF system designed for long range wireless remote control of electrical apparatus in a variety of industrial applications. Systems can consist of any number of receivers and handheld or contact input transmitters working together. The “461” series of receivers feature built-in repeating capability. They will listen for all transmissions from the control transmitter, perform commands if necessary and pass all commands on to any receiver within range. This receiver is equipped with 4 independent relays capable of switching 5 amps @ 120VAC or 30VDC, which can be directly interfaced with the customer’s equipment or P.L.C. Eight user selectable frequencies allow multiple systems to be used in the same area. The Air-Eagle XLT Plus can receive remote signals transmitted from up to 5000 feet away (with a handheld transmitter) or up to 10 miles away (with a stationary transmitter and external antennas).

### MODEL NOTES

This receiver was designed specifically to communicate with a “VBR” transmitter and features a confirmation signal that is sent back to the transmitter causing it to vibrate when its transmission has been received.

### INSTALLATION

1. Mount the AIR-EAGLE XLT PLUS RECEIVER in a convenient location.
2. Install relay control wiring to the terminal strip.
3. Attach rubber duck antenna or coax from external antenna to connector on side of enclosure.
4. Connect supplied power input cable to your external power source.

TERMINAL STRIP WIRING (TER1)		
Terminal 1	Negative (-) 9-36VDC	
Terminal 2	Positive (+) 9-36VDC	
Terminal 3	CH1 Dry Contact Input (Common)	Not used on this model
Terminal 4	CH1 Dry Contact Input	
Terminal 5	CH2 Dry Contact Input (Common)	
Terminal 6	CH2 Dry Contact Input	
Terminal 7	N/O Relay 1	
Terminal 8	C Relay 1	
Terminal 9	N/C Relay 1	
Terminal 10	N/O Relay 2	
Terminal 11	C Relay 2	
Terminal 12	N/C Relay 2	
Terminal 13	N/O Relay 3	
Terminal 14	C Relay 3	
Terminal 15	N/C Relay 3	
Terminal 16	N/O Relay 4	
Terminal 17	C Relay 4	
Terminal 18	N/C Relay 4	

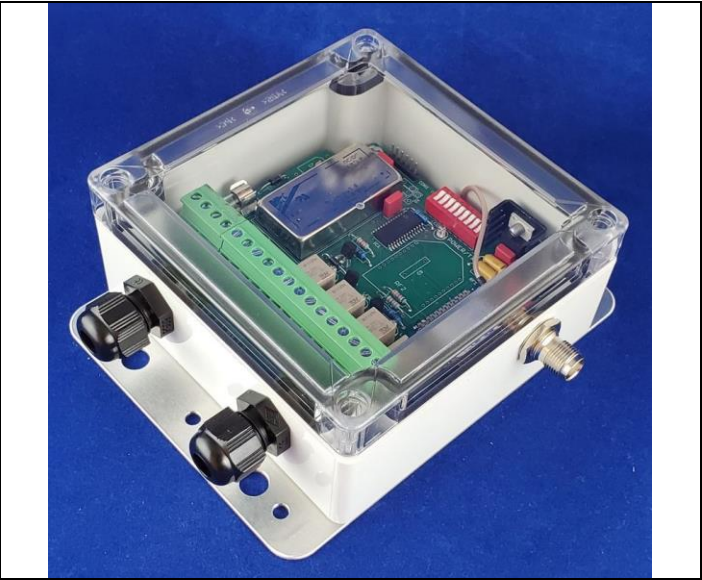

### CONTROLS & INDICATORS

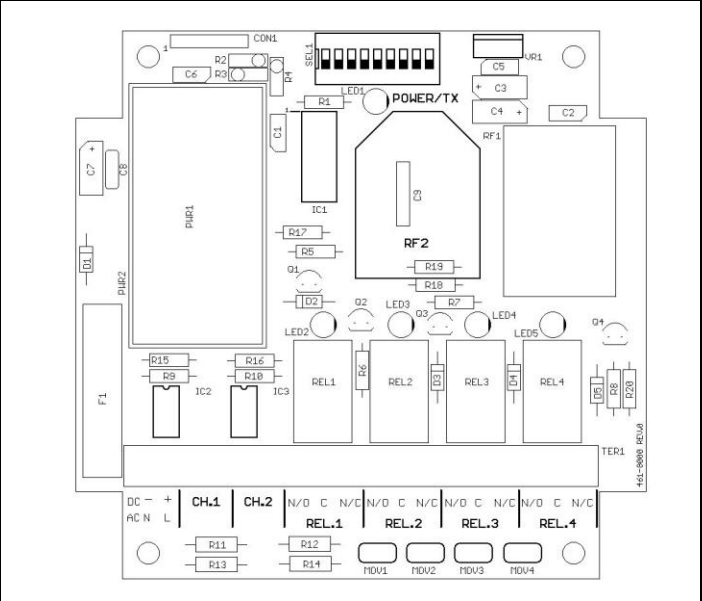

POWER/TX LED1	Dual color LED. Illuminates red while receiver is booting up; changes to green when boot-up is successful and unit is ready to operate. <b>If this LED fails to turn green, power unit off for 15-20 seconds, then reapply power.</b>
LED2	Illuminates green while relay 1 is energized
LED3	Illuminates green while relay 2 is energized
LED4	Illuminates green while relay 3 is energized
LED5	Illuminates green while relay 4 is energized
REL1 – REL4	Four SPDT output control relays
RF1	RF Module that transmits/receives data

# AIR-EAGLE® XLT PLUS

## High Power 900MHz RF Receiver

### MODEL 461-8000-VBR-DC

## RELAY OPERATION

Relays energize and de-energize based on commands received from the transmitter. See table below for relay mode configuration for this receiver:

TX Signal Received	Relay Function
Input 1 Closed	Relay 1 energizes, maintained momentary
Input 2 Closed	Relay 2 energizes, maintained momentary
Input 3 Closed	Relay 3 energizes, maintained momentary
Input 4 Closed	Relay 4 energizes, maintained momentary

## OPTIONS & FREQUENCY SET-UP

The unit is shipped from the factory with SEL1 switches in the open positions. All four relays will operate as maintained momentary and unit is receiving commands on frequency one. If you wish to change these default settings, follow the instructions on the table below.

- 1) Remove power from unit then remove top cover.
- 2) Select desired relay operation, network frequency and safety delay options using table below.
- 3) Reattach cover and apply power. Programming is now complete.

### RELAY CONFIGURATION

SEL1 SWITCH NUMBER	OPEN	CLOSED
SW1	Relay #1 momentary (default)	Relay #1 toggle/latch
SW2	Relay #2 momentary (default)	Relay #2 toggle/latch
SW3	Relay #3 momentary (default)	Relay #3 toggle/latch
SW4	Relay #4 momentary (default)	Relay #4 toggle/latch

**Maintained Momentary** – Relay mimics button or input – when depressed or closed, relay will be energized; when released, relay de-energizes

**Toggle Latch** – Relay changes (and holds) its state each time the corresponding button or input is depressed or closed.

### FREQUENCY SET-UP

SEL1 (SW5-7)	Network Frequency	SW5	SW6	SW7
	1 (default)	OPEN	OPEN	OPEN
	2	CLOSED	OPEN	OPEN
	3	OPEN	CLOSED	OPEN
	4	CLOSED	CLOSED	OPEN
	5	OPEN	OPEN	CLOSED
	6	CLOSED	OPEN	CLOSED
	7	OPEN	CLOSED	CLOSED
	8	CLOSED	CLOSED	CLOSED

### SAFETY DELAY TIMER

Time	SW8	SW9
5 Sec (Default)	OPEN	OPEN
30 Sec	CLOSED	OPEN
60 Sec	OPEN	CLOSED
90 Sec	CLOSED	CLOSED

The safety delay timer allows the unit to keep the relay active during periods of high interference or bad reception. This is the amount of time that a signal must be lost before turning off the relay. This also is a safety feature to turn off the relay if the relay off code is missed due to bad signal.

## APPROVALS

United States (FCC)	MCQ-XBPSX
Canada (IC)	1846A-XBPSX
Australia	RCM
Brazil	ANATEL 05774-16-01209

## SPECIFICATIONS

Power Supply	9-36 VDC, 5 W
Fuse Protected	2 amp
Relay Contacts	SPDT 5 amp @ 120VAC or 30VDC
Receiver Range	Up to 1 Mile with Rubber Duck Antenna / Up to 10 Miles with External Antenna
<small>Note: Range figures are estimates, based on free-air terrain with limited sources of interference. Actual range will vary based on transmitting power, orientation of transmitter and receiver, height of transmitting antenna, height of receiving antenna, weather conditions, interference sources in the area, and terrain between receiver and transmitter, including, but not limited to, indoor and outdoor structures such as walls, metal objects, trees, buildings, hills, and mountains.</small>	
Receiver Frequency	902 – 928 MHz Spread Spectrum
RF Networks	Eight Independent Network Frequencies
Enclosure	Polycarbonate, NEMA 4, IP66
Operating Temp	-40° F - +185° F

## DIMENSIONS

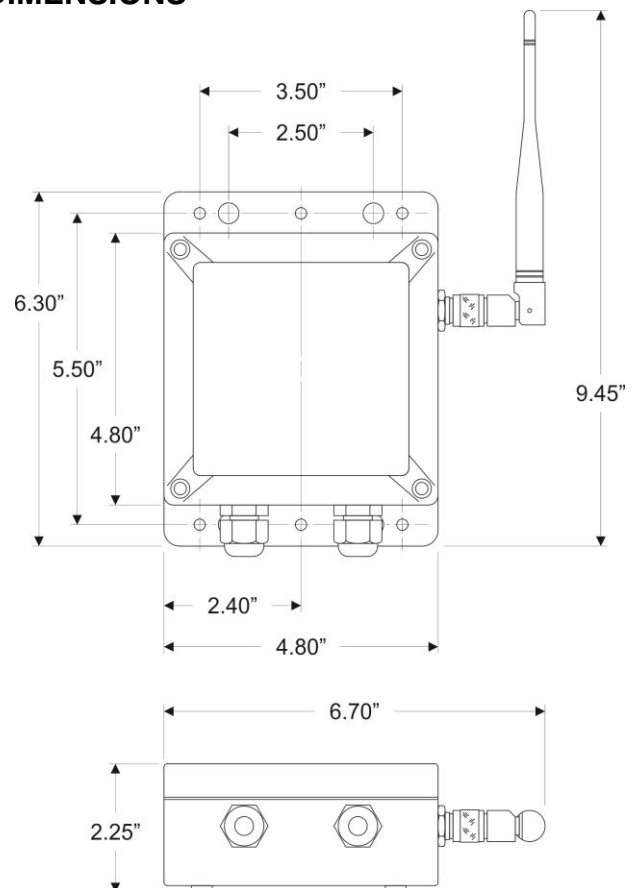

# AIR-EAGLE® XLT PLUS

High Power 900MHz RF Receiver

**MODEL 461-8000-VBR-AC**

## ACCESSORIES

Standard Antenna (Included):	
900MHz TNC "Rubber Duck" Antenna	49-1103
Mobile/Base Antennas – Used to help achieve max range in both non line of sight and line of sight applications. - Contact BWI Eagle for recommendations	
900MHz Thru-Hole Mount Mobile Antenna	49-2101
900MHz Magnet Mount Mobile Antenna	49-2102
900MHz Omni Directional Base Antenna	49-3101
900MHz Yagi Directional Base Antenna	49-3102
High Quality Coax Cables – Used to connect external high gain antennas to control unit	
Flex Coax Cable w/Connectors – Available in 5', 15', 25', 30', 40', 60', 80', 100' Lengths	49-4000-XX (XX = # of Feet)
Bulkhead Extensions – Used to provide an external antenna connection when mounting control unit inside another enclosure	
TNC Male to TNC Bulkhead Cable Assembly - Available in 2', 4', 7' Lengths	49-5004-X-ISO (X = # of Feet)

## LIMITED WARRANTY STATEMENT

BWI Eagle Inc. warrants the Air-Eagle Remote Control System, if properly used and installed, will be free from defects in material and workmanship for a period of **1 year** after date of purchase. Said warranty to include the repair or replacement of defective equipment. This warranty does not cover damage due to external causes, including accident, problems with electrical power, usage not in accordance with product instructions, misuse, neglect, alteration, repair, improper installation, or improper testing. This limited warranty, and any implied warranties that may exist under state law, apply only to the original purchaser of the equipment, and last only for as long as such purchaser continues to own the equipment. This warranty replaces all other warranties, express or implied including, but not limited to, the implied warranties or merchantability and fitness for a particular purpose. BWI Eagle makes no express warranties beyond those stated here. BWI disclaims without limitation, implied warranties of merchantability and fitness for a particular purpose. Some jurisdictions do not allow the exclusion of implied warranties so this limitation may not apply to you. To obtain warranty service, contact BWI Eagle for a return material authorization. When returning equipment to BWI Eagle, the customer assumes the risk of damage or loss during shipping and is responsible for the shipping costs incurred.

DOCUMENT DATE: 07/22/2021 / PRODUCT REV. 1



105 Bonnie Drive  
Butler, PA 16002  
(724) 283-4681  
Fax (724) 283-5939  
[www.bwieagle.com](http://www.bwieagle.com)



105 Bonnie Drive  
Butler, PA 16002  
724-283-4681  
724-283-5939 (fax)  
www.bwieagle.com

# RELAY OUTPUT WIRING 4-Relay Receiver

Receiver outputs are dry relay contacts, like an SPDT switch. When the relay is in a de-energized state, the N/C (normally closed) contact is connected to C (common). When the relay is energized the N/O (normally open) contact is connected to C (common).

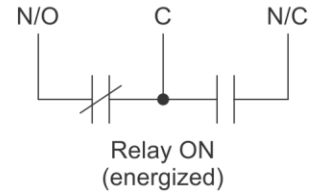
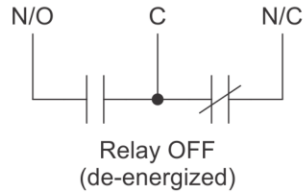

## Normally Open Application with Externally Supplied Voltage

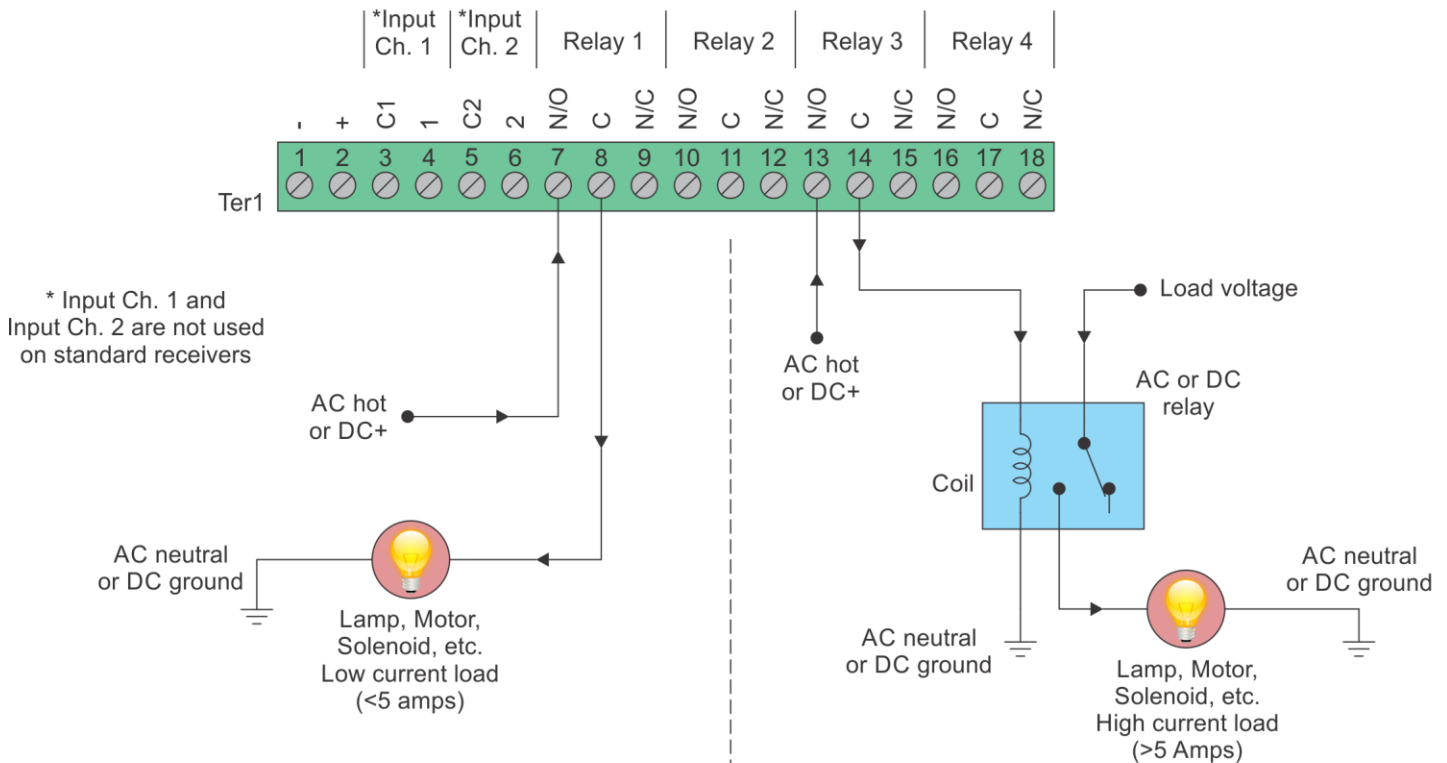

### Internal Relay - Loads Less Than 5 Amps

Loads up to 5 Amps may be wired directly to the internal relays. Wiring to the N/O contact will cause the load to turn on when the relay is energized (the load is on when the relay is on). Wiring to the N/C contact will cause the load to turn on when the relay is de-energized (the load is on when the relay is off). AC or DC voltages can be switched through the relay.

### External Relay - Loads Over 5 Amps

Loads over 5 Amps must use an external high current relay. Diagram shows how to turn on the relay using the lower current internal relay of the receiver. AC or DC voltages can be switched through the relay. Note: A protection diode for DC coils or an MOV for AC coils is recommended to reduce inductive EMI noise.

Wiring configurations shown here are examples. The wiring for your application may differ.  
Call BWI Eagle for assistance or consult an electrician.