



105 Bonnie Drive
Butler, PA 16002
724-283-4681
724-283-5939 (fax)
www.bwieagle.com

PRODUCT INFORMATION BULLETIN

AIR-EAGLE® XLT PLUS High Power 900MHz RF Receiver MODEL 461-5000-AC

DESCRIPTION

The AIR-EAGLE XLT PLUS is an RF system designed for long range wireless remote control of electrical apparatus in a variety of industrial applications. Systems can consist of any number of receivers and handheld or contact input transmitters working together. The "461" series of receivers feature built-in repeating capability. They will listen for all transmissions from the control transmitter, perform commands if necessary and pass all commands on to any receiver within range. This receiver is equipped with 3 independent relays, capable of switching 5 amps @ 120VAC or 30VDC, which can be directly interfaced with the customer's equipment or P.L.C. Seven user selectable frequencies allow multiple systems to be used in the same area. The Air-Eagle XLT Plus can receive remote signals transmitted from up to 5000 feet away (with a handheld transmitter) or up to 10 miles away (with a stationary transmitter and external high gain antennas).

INSTALLATION

1. Mount the AIR-EAGLE XLT PLUS RECEIVER in a convenient location.
2. Install relay control wiring to the terminal strip.
3. Attach rubber duck antenna or coax from external antenna to connector on side of enclosure.
4. Connect AC power to the proper terminals in your control circuit.

Make the following connections on the PC Board Terminal Strip (TER1)

TERMINAL STRIP WIRING (TER1)	
Terminal 1	120VAC – (Neutral)
Terminal 2	120VAC – (Hot)
Terminal 3	Not Used
Terminal 4	Not Used
Terminal 5	Not Used
Terminal 6	Not Used
Terminal 7	Not Used
Terminal 8	Not Used
Terminal 9	N/O Relay 1
Terminal 10	C Relay 1
Terminal 11	N/C Relay 1
Terminal 12	N/O Relay 2
Terminal 13	C Relay 2
Terminal 14	N/C Relay 2
Terminal 15	N/O Relay 3
Terminal 16	C Relay 3
Terminal 17	N/C Relay 3
Terminal 18	Not Used



DC Powered Model Pictured

CONTROLS & INDICATORS

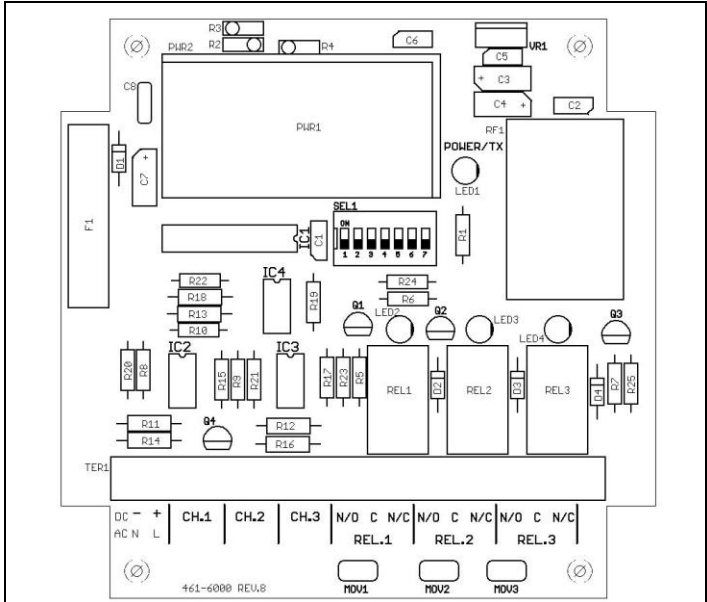

POWER/TX LED1	Dual color LED. Illuminates red while receiver is booting up; changes to green when boot-up is successful and unit is ready to operate. If this LED fails to turn green, power unit off for 15-20 seconds, then reapply power.
LED2	Illuminates green while relay 1 is energized
LED3	Illuminates green while relay 2 is energized
LED4	Illuminates green while relay 3 is energized
REL1, REL2, REL3	Three SPDT output control relays
RF1	RF Module that transmits/receives data

AIR-EAGLE® XLT PLUS

High Power 900MHz RF Receiver

MODEL 461-5000-AC

RELAY OPERATION

Relays energize and de-energize based on commands received from the transmitter. See table below for relay mode configuration for this receiver:

TX Signal Received	Relay Function
Input 1 Closed	Relay 1 energizes, maintained momentary
Input 2 Closed	Relay 2 energizes, maintained momentary
Input 3 Closed	Relay 3 energizes, maintained momentary

FREQUENCY & OPTIONS SET-UP

This unit is shipped from the factory with SEL1 switches in the open positions. The safety off-delay on all relays is 5 seconds and the unit is operating on frequency #1. If you wish to change the default setting, follow the instructions below:

- 1) Remove power from unit and remove top cover.
- 2) Select desired safety off-delay time and network frequency using table below.
- 3) Reattach cover and apply power. Programming is now complete.

FREQUENCY SELECTION

	Network Frequency	SW1	SW2	SW3
SEL 1 (SW1, 2 & 3):	#1 (default)	OPEN	OPEN	OPEN
	#2	CLOSED	OPEN	OPEN
	#3	OPEN	CLOSED	OPEN
	#4	CLOSED	CLOSED	OPEN
	#5	OPEN	OPEN	CLOSED
	#6	CLOSED	OPEN	CLOSED
	#7	OPEN	CLOSED	CLOSED

SAFETY OFF-DELAY SELECTION

	Off-Delay	SW4	SW5
SEL 1 (SW4 & 5):	5 Seconds (default)	OPEN	OPEN
	30 Seconds	CLOSED	OPEN
	1 Minute	OPEN	CLOSED
	1 ½ Minutes	CLOSED	CLOSED
SEL1 (SW6-7)	Not used on this model		

APPROVALS

United States (FCC)	MCQ-XBPSX
Canada (IC)	1846A-XBPSX

SPECIFICATIONS

Power Supply	110-240 VAC, 5 W, 50/60 Hz
Fuse Protected	2 amp
Relay Contacts	SPDT 5 amp @ 120VAC or 30VDC
Receiver Range	Approximately 1 Mile (Up to 10 miles with external antenna - see accessories)
Receiver Frequency	900MHz Spread Spectrum
RF Networks	Seven Independent Network Frequencies
Enclosure	Polycarbonate, NEMA 4, IP66
Operating Temp	-40° F - +185° F

DIMENSIONS

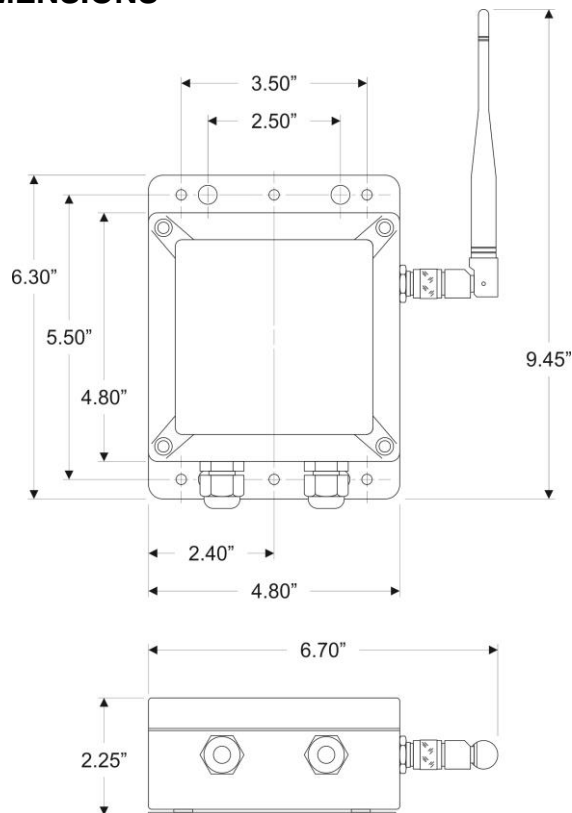

REPLACEMENT PARTS & ACCESSORIES

PC Board (Main)	461-5002-AC
Standard Antenna (Included):	
900MHz Portable Antenna (For distances up to 1 Mile*)	49-1103
Optional Antennas and Accessories:	
900MHz Omni Directional Antenna (For distances up to 5 miles*)	49-3101
900MHz 13dB Yagi Antenna Long Range Operation (For distances up to 10 miles*)	49-3102
Flex Coax Cable w/Connectors	49-4000-XX (XX = # of Feet)
* = Line of Sight	

LIMITED WARRANTY STATEMENT

BWI Eagle Inc. warrants the Air-Eagle Remote Control System, if properly used and installed, will be free from defects in material and workmanship for a period of **1 year** after date of purchase. Said warranty to include the repair or replacement of defective equipment. This warranty does not cover damage due to external causes, including accident, problems with electrical power, usage not in accordance with product instructions, misuse, neglect, alteration, repair, improper installation, or improper testing. This limited warranty, and any implied warranties that may exist under state law, apply only to the original purchaser of the equipment, and last only for as long as such purchaser continues to own the equipment. This warranty replaces all other warranties, express or implied including, but not limited to, the implied warranties of merchantability and fitness for a particular purpose. BWI Eagle makes no express warranties beyond those stated here. BWI disclaims without limitation, implied warranties of merchantability and fitness for a particular purpose. Some jurisdictions do not allow the exclusion of implied warranties so this limitation may not apply to you. To obtain warranty service, contact BWI Eagle for a return material authorization. When returning equipment to BWI Eagle, the customer assumes the risk of damage or loss during shipping and is responsible for the shipping costs incurred.