



105 Bonnie Drive
Butler, PA 16002
724-283-4681
724-283-5939 (fax)
www.bwieagle.com

PRODUCT INFORMATION BULLETIN

AIR-EAGLE® XLT PLUS High Power 900MHz RF Repeater MODEL 461-4500-AC

DESCRIPTION

The AIR-EAGLE XLT PLUS RF REPEATER IS designed to retransmit an RF signal from any Air-Eagle XLT PLUS Transmitter. When placed in an area where the signal is weak, this unit will then re-transmit at full strength facilitating greater distances and allowing the RF signal to reach around corners, through tunnels, over hills and through valleys.

APPROVALS

United States (FCC)	MCQ-XBPSX
Canada (IC)	1846A-XBPSX

INSTALLATION

DISCONNECT Power from all equipment before installation.

1. Mount the AIR-EAGLE XLT PLUS REPEATER in a convenient location.
2. Attach rubber duck antenna or coax from external antenna to connector on side of enclosure.
3. Connect AC power to the proper terminals in your control circuit.

TERMINAL STRIP WIRING

TERMINAL STRIP WIRING (TER1)	
Terminal 1	120VAC – (Neutral)
Terminal 2	120VAC – (Hot)
Terminal 3	Not Used
Terminal 4	Not Used
Terminal 5	Not Used
Terminal 6	Not Used
Terminal 7	Not Used
Terminal 8	Not Used
Terminal 9	Not Used
Terminal 10	Not Used
Terminal 11	Not Used
Terminal 12	Not Used
Terminal 13	Not Used
Terminal 14	Not Used
Terminal 15	Not Used
Terminal 16	Not Used
Terminal 17	Not Used
Terminal 18	Not Used



CONTROLS & INDICATORS

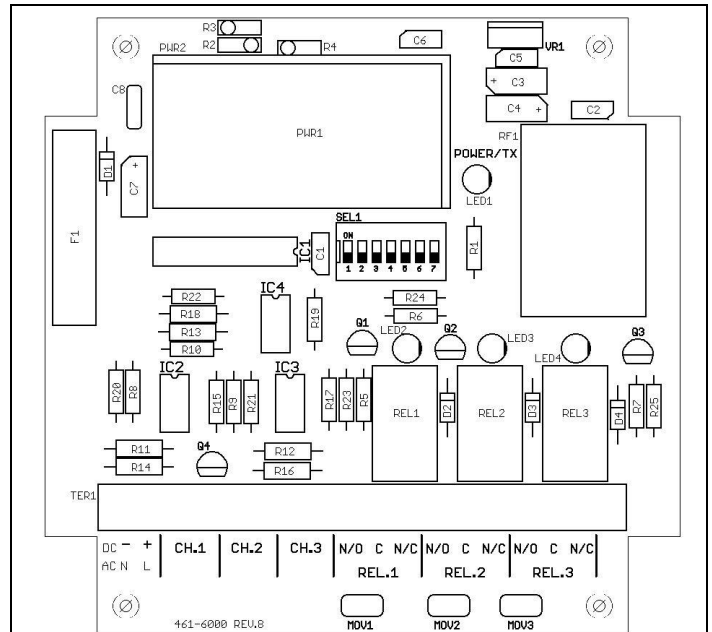

RX LED	Yellow LED illuminates as remote signals are being received by the repeater
POWER LED	Green LED is illuminated while power is applied to the repeater
TX LED	Red LED illuminates as remote signals are being re-transmitted by the repeater
RF1	RF module that receives data from the remote transmitter
SEL1	Used to set frequency

AIR-EAGLE® XLT PLUS

High Power 900MHz RF Repeater

MODEL 461-4500-AC

FREQUENCY SET-UP

This unit is shipped from the factory with SEL1 switches in the open positions and is operating on frequency #1. If you wish to change the default frequency setting, follow the instructions below:

- 1) Remove power from unit
- 2) Remove top cover.
- 3) Select desired network frequency using table below.
- 4) Reattach cover and apply power.
- 5) Programming is now complete.

FREQUENCY SELECTION

	Network Frequency	SW1	SW2	SW3
SEL 1 (SW1, 2 & 3):	#1 (default)	OPEN	OPEN	OPEN
	#2	CLOSED	OPEN	OPEN
	#3	OPEN	CLOSED	OPEN
	#4	CLOSED	CLOSED	OPEN
	#5	OPEN	OPEN	CLOSED
	#6	CLOSED	OPEN	CLOSED
	#7	OPEN	CLOSED	CLOSED
SEL1 (SW4-7)	Not used on this model			

DIMENSIONS

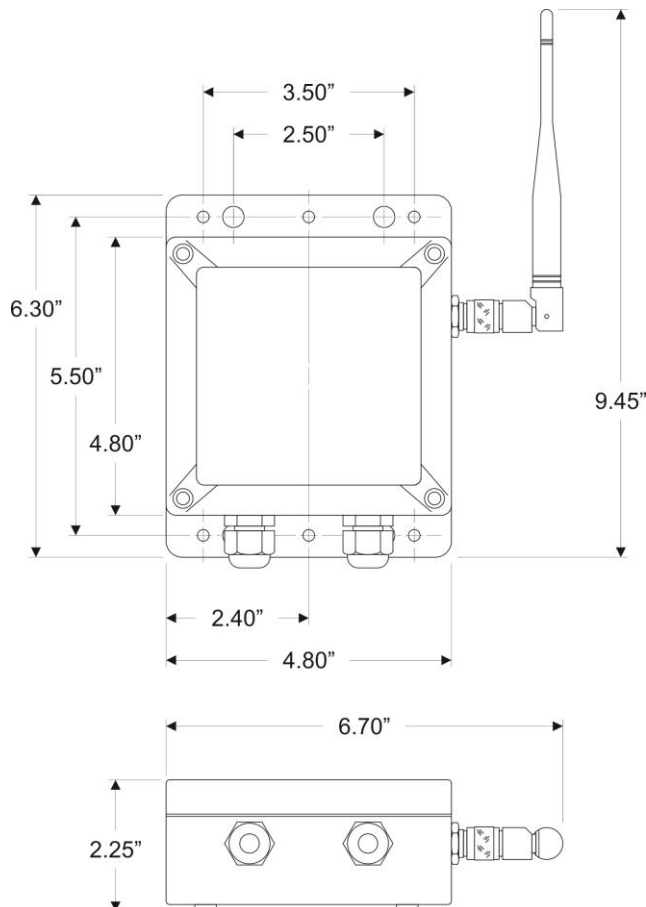

SPECIFICATIONS

Power Supply	110-240 VAC, 5 W, 50/60 Hz
Fuse Protected	2 amp
Frequency	900MHz Spread Spectrum
RF Networks	Seven Independent Network Frequencies
RF Output Power	1W
Transmit Range	Approximately 1 Mile (Up to 10 miles with external antenna - see accessories)
Transmitter Data	Repeater
Enclosure	Polycarbonate, IP66 (NEMA 4)
Operating Temp	-40° F - +185° F

REPLACEMENT PARTS & ACCESSORIES

PC Board (Main)	461-4502-AC
Standard Antenna (Included):	
900MHz Portable Antenna (For distances up to 1 Mile*)	49-1103
Optional Antennas and Accessories:	
900MHz Omni Directional Antenna (For distances up to 5 miles*)	49-3101
900MHz 13dB Yagi Antenna Long Range Operation (For distances up to 10 miles*)	49-3102
Flex Coax Cable w/Connectors	49-4000-XX (XX = # of Feet)
* = Line of Sight	

LIMITED WARRANTY STATEMENT

BW1 Eagle Inc. warrants the Air-Eagle Remote Control System, if properly used and installed, will be free from defects in material and workmanship for a period of **1 year** after date of purchase. Said warranty to include the repair or replacement of defective equipment. This warranty does not cover damage due to external causes, including accident, problems with electrical power, usage not in accordance with product instructions, misuse, neglect, alteration, repair, improper installation, or improper testing. This limited warranty, and any implied warranties that may exist under state law, apply only to the original purchaser of the equipment, and last only for as long as such purchaser continues to own the equipment. This warranty replaces all other warranties, express or implied including, but not limited to, the implied warranties or merchantability and fitness for a particular purpose. BW1 Eagle makes no express warranties beyond those stated here. BW1 disclaims without limitation, implied warranties of merchantability and fitness for a particular purpose. Some jurisdictions do not allow the exclusion of implied warranties so this limitation may not apply to you. To obtain warranty service, contact BW1 Eagle for a return material authorization. When returning equipment to BW1 Eagle, the customer assumes the risk of damage or loss during shipping and is responsible for the shipping costs incurred.

DOCUMENT DATE: 04/23/2019 / PRODUCT REV. 5



105 Bonnie Drive
Butler, PA 16002
(724) 283-4681
Fax (724) 283-5939
www.bwieagle.com