



105 Bonnie Drive  
Butler, PA 16002  
724-283-4681  
724-283-5939 (fax)  
www.bwieagle.com

# PRODUCT INFORMATION BULLETIN

## AIR-EAGLE® XLT PLUS 900MHz RF Receiver MODEL 461-20800-DC

### DESCRIPTION

The AIR-EAGLE XLT PLUS is an RF system designed for long range wireless remote control of electrical apparatus in a variety of industrial applications. Systems can consist of any number of transmitters and receivers working together. This receiver is equipped with 8 independent relays that can switch 5 amps @ 120VAC or 30VDC and can be directly interfaced with the customer's equipment or P.L.C. Seven user selectable frequencies allow multiple systems to be used in the same area. The Air-Eagle XLT Plus can receive remote signals transmitted from up to 3500 feet away (with a handheld transmitter) or up to 10 miles away (with a stationary transmitter and external high gain antennas).

### SERIES FEATURE

The "461" series features built-in repeating capability. Each receiver accepts and performs commands from the transmitter then repeats the commands to any other receiver within its range. When using multiple receivers this increases range and reliability because if there is a receiver that the transmitter can't quite reach but is within range of another receiver that HAS gotten the signal, it will still get its command from that receiver.

### INSTALLATION

DISCONNECT DC Power from all equipment before installation.

1. Mount the AIR-EAGLE XLT PLUS RECEIVER in a convenient location.
2. Install relay wiring to terminal strip.
3. Install antenna onto antenna connector located on the right side on the enclosure.
4. Connect DC power to the proper terminals in your control circuit.

### TERMINAL STRIP WIRING

1	N/O Relay #1	10	N/O Relay #4	19	N/O Relay #7
2	C Relay #1	11	C Relay #4	20	C Relay #7
3	N/C Relay #1	12	N/C Relay #4	21	N/C Relay #7
4	N/O Relay #2	13	N/O Relay #5	22	N/O Relay #8
5	C Relay #2	14	C Relay #5	23	C Relay #8
6	N/C Relay #2	15	N/C Relay #5	24	N/C Relay #8
7	N/O Relay #3	16	N/O Relay #6		
8	C Relay #3	17	C Relay #6		
9	N/C Relay #3	18	N/C Relay #6		

DC INPUT	
Terminal #1	Negative (-) 9-36VDC INPUT
Terminal #2	Positive (+) 9-36VDC INPUT



### DIMENSIONS

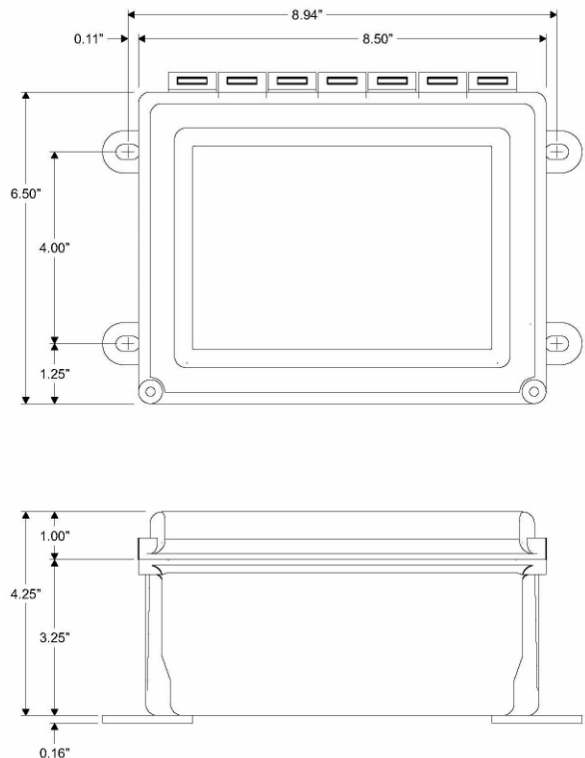

### APPROVALS

United States (FCC)	OUR-9XTEND
Canada (IC)	4214A-9XTEND

# AIR-EAGLE® XLT PLUS

900MHz RF Receiver

**MODEL 461-20800-DC**

## RELAY & FREQUENCY SET-UP

This unit is shipped from the factory with the SEL1 switches in the open positions. All eight relays will operate in a maintained momentary manor, and unit is receiving commands on frequency one. If you wish to change these default settings, follow the instructions on the table below.

- 1) Remove power from unit
- 2) Remove top cover.
- 3) Select desired relay operation and/or network frequency using table below.
- 4) Reattach cover and apply power.
- 5) Programming is now complete.

### RELAY CONFIGURATION

SEL1 SWITCH NUMBER	OPEN	CLOSED
SW1	Relays #1 thru #8 maintained momentary (default)	Relays #1 thru #8 toggle/latch
SW2	Not used on this model	
<b>Maintained Momentary</b> – Relay mimics button or input – when depressed or closed, relay will be energized; when released, relay de-energizes		
<b>Toggle Latch</b> – Relay changes (and holds) its state each time the corresponding button or input is depressed or closed.		
SW3	Vibrating Feedback OFF (default)	Vibrating Feedback ON
SW4	Not used on this model	

### FREQUENCY SET-UP

SEL1 (SW5-7)	Network Frequency	SW5	SW6	SW7
	1 (default)	OPEN	OPEN	OPEN
	2	CLOSED	OPEN	OPEN
	3	OPEN	CLOSED	OPEN
	4	CLOSED	CLOSED	OPEN
	5	OPEN	OPEN	CLOSED
	6	CLOSED	OPEN	CLOSED
	7	OPEN	CLOSED	CLOSED

## GENERAL OPERATION

Relays #1 thru #8 energize or de-energize based on specific commands from a handheld or contact input transmitter.

BUTTON OR INPUT ACTIVATED	RELAY OPERATION
"1"	Relay #1 energizes, maintained momentary
"2"	Relay #2 energizes, maintained momentary
"3"	Relay #3 energizes, maintained momentary
"4"	Relay #4 energizes, maintained momentary
"5"	Relay #5 energizes, maintained momentary
"6"	Relay #6 energizes, maintained momentary
"7"	Relay #7 energizes, maintained momentary
"8"	Relay #8 energizes, maintained momentary

## SPECIFICATIONS

DC Input	9 - 36 VDC @ 10 Watts
Fuse Protected	1 amp
Relay Contacts	SPDT 5 amp @ 120VAC or 30VDC per channel
Receiver Range	Approximately 1 Mile (Up to 10 miles with external antenna - see accessories)
Receiver Frequency	900 MHz Spread Spectrum
RF Channels	Seven independent network frequencies
Enclosure	Hinged fiberglass with window / NEMA 3, 3R, 4, 12, 13
Operating Temp	-40° F to +185° F

## REPLACEMENT PARTS & ACCESSORIES

PC Board (Main)	461-20802-DC
Standard Antenna (Included):	
900MHz Portable Antenna (For distances up to 1 Mile*)	49-1103
Optional Antennas and Accessories:	
900MHz Omni Directional Antenna (For distances up to 5 miles*)	49-3101
900MHz 13dB Yagi Antenna Long Range Operation (For distances up to 10 miles*)	49-3102
Flex Coax Cable w/Connectors	49-4000-XX (XX = # of Feet)
* = Line of Sight	

## LIMITED WARRANTY STATEMENT

BWI Eagle Inc. warrants the Air-Eagle XLT Remote Control System, if properly used and installed, will be free from defects in material and workmanship for a period of 1 year after date of purchase. Said warranty to include the repair or replacement of defective equipment. This warranty does not cover damage due to external causes, including accident, problems with electrical power, usage not in accordance with product instructions, misuse, neglect, alteration, repair, improper installation, or improper testing. This limited warranty, and any implied warranties that may exist under state law, apply only to the original purchaser of the equipment, and last only for as long as such purchaser continues to own the equipment. This warranty replaces all other warranties, express or implied including, but not limited to, the implied warranties or merchantability and fitness for a particular purpose. BWI Eagle makes no express warranties beyond those stated here. BWI disclaims without limitation, implied warranties of merchantability and fitness for a particular purpose. Some jurisdictions do not allow the exclusion of implied warranties so this limitation may not apply to you. To obtain warranty service, contact BWI Eagle for a return material authorization. When returning equipment to BWI Eagle, the customer assumes the risk of damage or loss during shipping and is responsible for the shipping costs incurred.

DOCUMENT DATE: 3/26/18 / PRODUCT REV.2



105 Bonnie Drive  
Butler, PA 16002  
(724) 283-4681  
Fax (724) 283-5939  
[www.bwieagle.com](http://www.bwieagle.com)