



105 Bonnie Drive
Butler, PA 16002
724-283-4681
724-283-5939 (fax)
www.bwieagle.com

PRODUCT INFORMATION BULLETIN

AIR-EAGLE® XLT 900 MHz RF Transmitter MODEL 461-1400-AC

DESCRIPTION

The AIR-EAGLE XLT PLUS TX is an R.F. transmitter capable of sending four independent dry-contact input commands to an Air-Eagle XLT Receiver located up to 1 mile away (longer ranges can be achieved with external high gain antennas) Any number of transmitters and receivers can be combined to create a long-range radio frequency system that operates hazardous or hard-to-reach electrical apparatus from safe, convenient locations. Eight user-selectable frequencies allow multiple systems to operate simultaneously in the same area without interference.

APPROVALS

United States (FCC)	MCQ-XB900HP
Canada (IC)	1846A-XB900HP

INSTALLATION

DISCONNECT Power from all equipment before installation.

1. Mount the transmitter in a convenient location.
2. Install input wiring to terminal strip.
3. Install antenna onto antenna connector located on the right side on the enclosure.
4. Connect supplied power input cable to your external power source.

TERMINAL STRIP WIRING

Wire as shown based on number of contact inputs									
1	2	3	4	5	6	7	8	9	10
C Input 1	Input 1	C Input 2	Input 2	C Input 3	Input 3	C Input 4	Input 4	100-250 VAC (N) Power Input	100-250 VAC (H) Power Input

GENERAL OPERATION

A closure on any input transmits its channel command to activate the corresponding relay in the remote receiver. The transmission continues as long as the input is closed and ceases when the input opens.



Dimensions (with mounting plate) 6.3" L x 4.8" W x 2.3" H

CONTROLS & INDICATORS

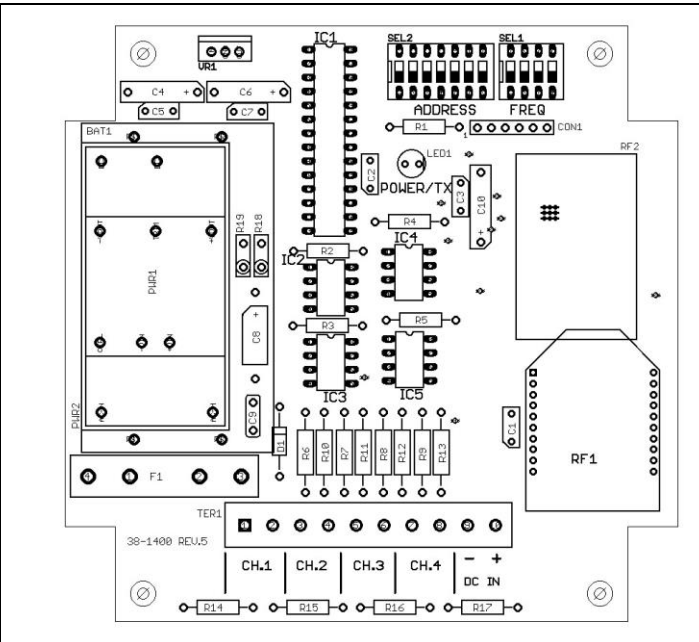

TX LED	Illuminates green when power is applied. Changes to red while any contact input is closed and unit is transmitting.
Dry Contact Inputs	Transmits individual RF codes to the receiver
SEL2	Dip switch bank for digital address selection
SEL1	Dip switch bank for frequency & repeater mode selection

AIR-EAGLE® XLT PLUS

900 MHz RF Transmitter

MODEL 461-1400-AC

DIGITAL ADDRESS & FREQUENCY SET-UP

The unit is shipped from the factory with all SEL1 and SEL2 switches in the open positions. By default it is operating on Digital Address #1 and Frequency #1. If you wish to transmit on a different address and/or frequency, follow the instructions on the table below.

Note – only change digital address if using with a digitally addressable receiver. Otherwise, the digital address must be kept at the default of Digital Address “1”.

- 1) Remove power from unit and remove top cover.
- 2) Select desired digital address and network frequency using tables below.
- 3) Reattach cover and apply power. Programming is now complete.

DIGITAL ADDRESS SET-UP

SEL2 (SW1 – 4)

Digital Address	SW1	SW2	SW3	SW4
1 (default)	OPEN	OPEN	OPEN	OPEN
2	CLOSED	OPEN	OPEN	OPEN
3	OPEN	CLOSED	OPEN	OPEN
4	CLOSED	CLOSED	OPEN	OPEN
5	OPEN	OPEN	CLOSED	OPEN
6	CLOSED	OPEN	CLOSED	OPEN
7	OPEN	CLOSED	CLOSED	OPEN
8	CLOSED	CLOSED	CLOSED	OPEN
9	OPEN	OPEN	OPEN	CLOSED
10	CLOSED	OPEN	OPEN	CLOSED
11	OPEN	CLOSED	OPEN	CLOSED
12	CLOSED	CLOSED	OPEN	CLOSED
13	OPEN	OPEN	CLOSED	CLOSED
14	CLOSED	OPEN	CLOSED	CLOSED
15	OPEN	CLOSED	CLOSED	CLOSED
16	CLOSED	CLOSED	CLOSED	CLOSED

SEL2 (SW5-7) – Leave in OPEN position!!

FREQUENCY SET-UP

SEL1 (SW1-3)

Network Frequency	SW1	SW2	SW3
1 (default)	OPEN	OPEN	OPEN
2	CLOSED	OPEN	OPEN
3	OPEN	CLOSED	OPEN
4	CLOSED	CLOSED	OPEN
5	OPEN	OPEN	CLOSED
6	CLOSED	OPEN	CLOSED
7	OPEN	CLOSED	CLOSED
8	CLOSED	CLOSED	CLOSED

Note – SW4 not used on this model

SPECIFICATIONS

AC Input	100-250 VAC, 5 W, 50/60 Hz
Fuse Protected	2 amp
Transmitter Data	Four DRY Contact Inputs
Transmit Frequency	900MHz Spread Spectrum
RF Channels	Seven independent network frequencies
RF Output Power	1 Watt
Transmit Range	Up to 1 Mile with Rubber Duck Antenna / Up to 10 Miles with External High Gain Antenna
<small>Note: Max range figures are estimates, based on free-air terrain with limited sources of interference. Actual range will vary based on transmitting power, orientation of transmitter and receiver, height of transmitting antenna, height of receiving antenna, weather conditions, interference sources in the area, and terrain between receiver and transmitter, including, but not limited to, indoor and outdoor structures such as walls, metal objects, trees, buildings, hills, and mountains.</small>	
Enclosure	Polycarbonate, IP66 (NEMA 4)
Operating Temp	-40° F - +185° F

ACCESSORIES

Standard Antenna (Included):	
900MHz TNC “Rubber Duck” Antenna	49-1103
High Gain Antennas – Used to help achieve max range in both non line of sight and line of sight applications. - Contact BWI Eagle for recommendations	
900MHz Thru-Hole Mount Omni Directional Antenna	49-2101
900MHz Magnet Mount Omni Directional Antenna	49-2102
900MHz Omni Directional Antenna	49-3101
900MHz Yagi Antenna	49-3102
High Quality Coax Cables – Used to connect external high gain antennas to control unit	
Flex Coax Cable w/Connectors – Available in 5', 15', 25', 30', 40', 60', 80', 100' Lengths	49-4000-XX (XX = # of Feet)
Bulkhead Extensions – Used to provide an external antenna connection when mounting control unit inside another enclosure	
TNC Male to TNC Bulkhead Cable Assembly - Available in 2', 4', 7' Lengths	49-5004-X-ISO

LIMITED WARRANTY STATEMENT

BWI Eagle Inc. warrants the Air-Eagle Remote Control System, if properly used and installed, will be free from defects in material and workmanship for a period of 1 year after date of purchase. Said warranty to include the repair or replacement of defective equipment. This warranty does not cover damage due to external causes, including accident, problems with electrical power, usage not in accordance with product instructions, misuse, neglect, alteration, repair, improper installation, or improper testing. This limited warranty, and any implied warranties that may exist under state law, apply only to the original purchaser of the equipment, and last only for as long as such purchaser continues to own the equipment. This warranty replaces all other warranties, express or implied including, but not limited to, the implied warranties or merchantability and fitness for a particular purpose. BWI Eagle makes no express warranties beyond those stated here. BWI disclaims without limitation, implied warranties of merchantability and fitness for a particular purpose. Some jurisdictions do not allow the exclusion of implied warranties so this limitation may not apply to you. To obtain warranty service, contact BWI Eagle for a return material authorization. When returning equipment to BWI Eagle, the customer assumes the risk of damage or loss during shipping and is responsible for the shipping costs incurred.



105 Bonnie Drive
Butler, PA 16002
724-283-4681
724-283-5939 (fax)
www.bwieagle.com

DRY CONTACT INPUT WIRING 4-Input Transmitter

Standard wiring of a dry contact input transmitter

Shorting together the contacts of the respective channel will cause it to transmit. This can be done with any type of manual or automatic switch.

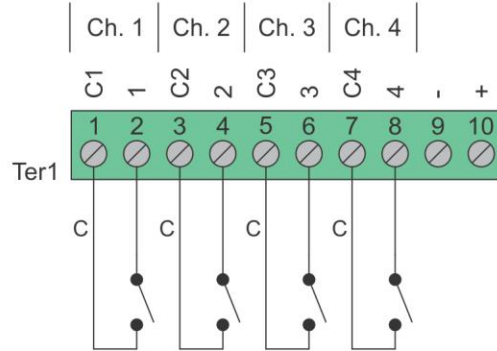

Standard Wiring for Common Ground Applications

Because each channel shares a common (C) terminal, inputs can be wired as shown to allow for fewer conductors to be run to the transmitter.

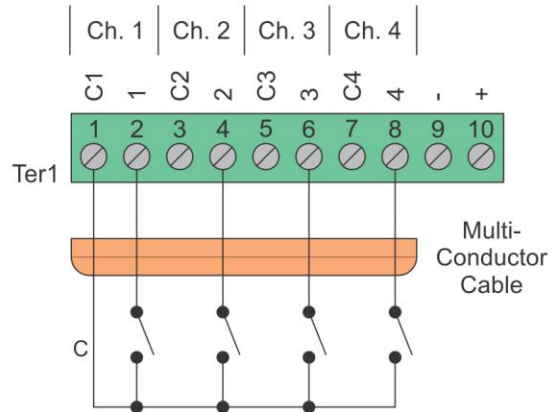

SPDT Switches

The common (C) terminal of the switch only needs to be connected to one of the channels ground terminal. In this configuration two channels would be transmitting all the time. A switch with a center "off" position would allow transmitting to stop. In this example channels 2 and 4 are transmitting.

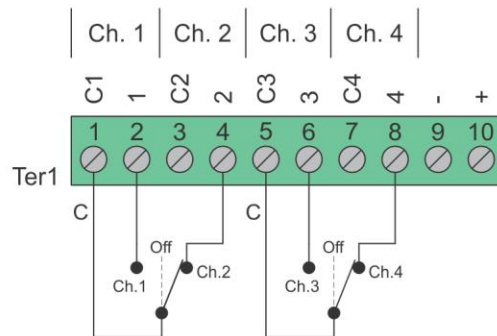

Wiring configurations shown here are examples. The wiring for your application may differ.
Call BWI Eagle for assistance or consult an electrician.