



105 Bonnie Drive
Butler, PA 16002
724-283-4681
724-283-5939 (fax)
www.bwieagle.com

PRODUCT INFORMATION BULLETIN

AIR-EAGLE® XLT PLUS High Power 900 MHz RF Transmitter REMOTE STOP SWITCH MODEL 461-1200-AC

DESCRIPTION

The AIR-EAGLE XLT PLUS TX is an R.F. transmitter designed to send a single stop command to any Air-Eagle XLT PLUS Receiver located up to a mile away (*). Any number of transmitters and receivers can be combined to create a long range radio frequency system that operates hazardous or hard-to-reach electrical apparatus from safe, convenient locations. Seven user-selectable frequencies allow multiple systems to operate simultaneously in the same area without interference. (*) - Longer distances can be achieved by using external antennas). Note: This product is not designed for use in life-saving applications.

APPROVALS

United States (FCC)	MCQ-XBPSX
Canada (IC)	1846A-XBPSX

INSTALLATION

1. Mount the AIR-EAGLE XLT PLUS TRANSMITTER in a convenient location.
2. Attach rubber duck antenna or coax from external antenna to connector on side of enclosure.
3. Connect supplied AC power input cable to your external power supply

PC BOARD SET-UP INFORMATION

This unit has had an E-Stop button factory installed on input #1.

TERMINAL STRIP WIRING (TER1)	
Terminal 1	100-250 VAC Power Input
Terminal 2	100-250 VAC Power Input
Terminal 3	CH1 Dry Contact Input (Common)
Terminal 4	CH1 Dry Contact Input
Terminal 5	CH2 Dry Contact Input (Common)
Terminal 6	CH2 Dry Contact Input
Terminal 7	CH3 Dry Contact Input (Common)
Terminal 8	CH3 Dry Contact Input
Terminal 9	Not Used
Terminal 10	Not Used
Terminal 11	Not Used
Terminal 12	Not Used
Terminal 13	Not Used
Terminal 14	Not Used
Terminal 15	Not Used
Terminal 16	Not Used
Terminal 17	Not Used
Terminal 18	Not Used



CONTROLS & INDICATORS

POWER / TX LED	Green LED illuminates continuously while power is applied – Turns to Red when unit is transmitting
STOP Pushbutton	Transmits an CH1 RF "STOP" code to the receiver

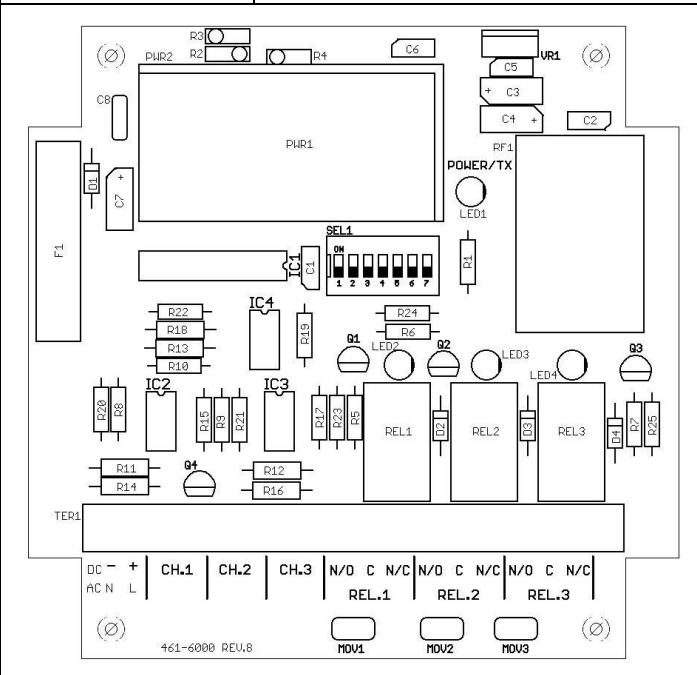

RF1	RF module that receives data from the remote transmitter
SEL1	Used to set frequency

AIR-EAGLE® XLT PLUS

High Power 900 MHz RF Transmitter
DUAL CONTACT INPUT

MODEL 461-1200-AC

FREQUENCY SET-UP

NETWORK SWITCH OPTIONS (SEL1)				
SEL 1 SW1, 2 & 3):	Network Frequency	SW1	SW2	SW3
<i>USED TO SET NETWORK FREQUENCY ADDRESS</i>	#1 (default)	OPEN	OPEN	OPEN
	#2	CLOSED	OPEN	OPEN
	#3	OPEN	CLOSED	OPEN
	#4	CLOSED	CLOSED	OPEN
	#5	OPEN	OPEN	CLOSED
	#6	CLOSED	OPEN	CLOSED
	#7	OPEN	CLOSED	CLOSED
	#8	CLOSED	CLOSED	CLOSED

DIMENSIONS

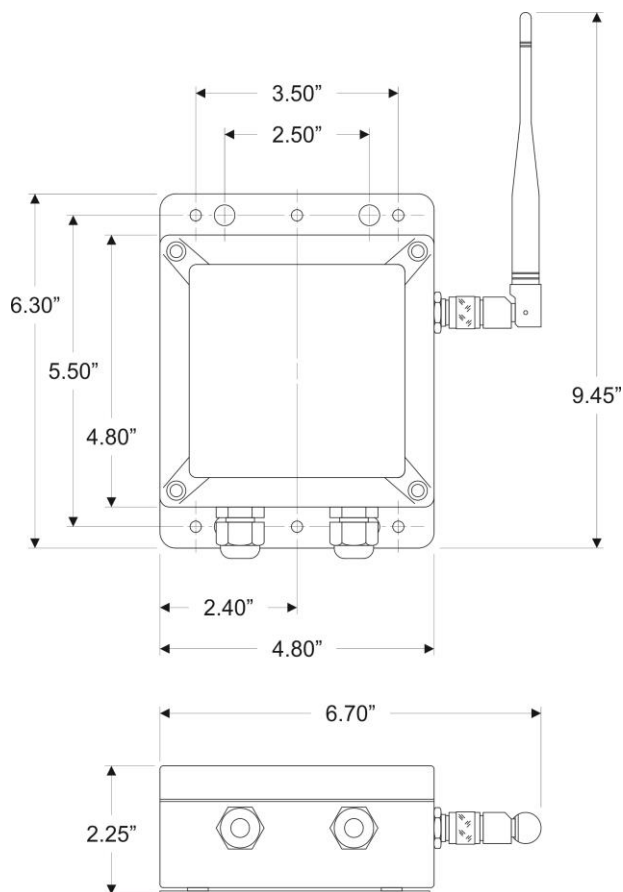

SPECIFICATIONS

Power Supply	100-250 VAC, 5 W, 50/60 Hz
Fuse Protected	2 amp
Transmitter Data	Dry Contact Input
Transmit Frequency	900MHz Spread Spectrum
RF Networks	Seven Independent Network Frequencies
RF Output Power	1 Watt
Transmit Range	Approximately 1 Mile with Rubber Duck Antenna / Up to 10 Miles with External High Gain Antenna
Enclosure	Polycarbonate, IP66 (NEMA 4)
Operating Temp	-40° F - +185° F

REPLACEMENT PARTS & ACCESSORIES

PC Board (Main)	461-1202-AC
Standard Antenna (Included):	
900MHz Portable Antenna (For distances up to 1 mile)	49-1103
Optional Antennas and Accessories:	
900MHz Omni Directional Antenna (For distances up to 5 miles*)	49-3101
900MHz 13dB Yagi Antenna Long Range Operation (For distances up to 10 miles*)	49-3102
Flex Coax Cable w/Connectors	49-4000-XX (XX = # of Feet)
* = Line of Sight	

LIMITED WARRANTY STATEMENT

BWI Eagle Inc. warrants the Air-Eagle Remote Control System, if properly used and installed, will be free from defects in material and workmanship for a period of **1 year** after date of purchase. Said warranty to include the repair or replacement of defective equipment. This warranty does not cover damage due to external causes, including accident, problems with electrical power, usage not in accordance with product instructions, misuse, neglect, alteration, repair, improper installation, or improper testing. This limited warranty, and any implied warranties that may exist under state law, apply only to the original purchaser of the equipment, and last only for as long as such purchaser continues to own the equipment. This warranty replaces all other warranties, express or implied including, but not limited to, the implied warranties or merchantability and fitness for a particular purpose. BWI Eagle makes no express warranties beyond those stated here. BWI disclaims without limitation, implied warranties of merchantability and fitness for a particular purpose. Some jurisdictions do not allow the exclusion of implied warranties so this limitation may not apply to you. To obtain warranty service, contact BWI Eagle for a return material authorization. When returning equipment to BWI Eagle, the customer assumes the risk of damage or loss during shipping and is responsible for the shipping costs incurred.

DOCUMENT DATE: 07/20/2020 / PRODUCT REV. 7



105 Bonnie Drive
Butler, PA 16002
(724) 283-4681
Fax (724) 283-5939
www.bwieagle.com



105 Bonnie Drive
Butler, PA 16002
724-283-4681
724-283-5939 (fax)
www.bwieagle.com

DRY CONTACT INPUT WIRING 3-Input Transmitter

Standard wiring of a dry contact input transmitter

Shorting together the contacts of the respective channel will cause it to transmit. This can be done with any type of manual or automatic switch.

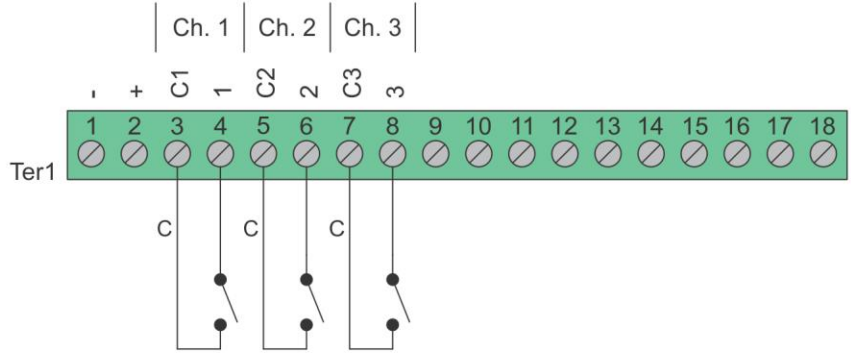

Standard Wiring for Common Ground Applications

Because each channel shares a common (C) terminal, inputs can be wired as shown to allow for fewer conductors to be run to the transmitter.

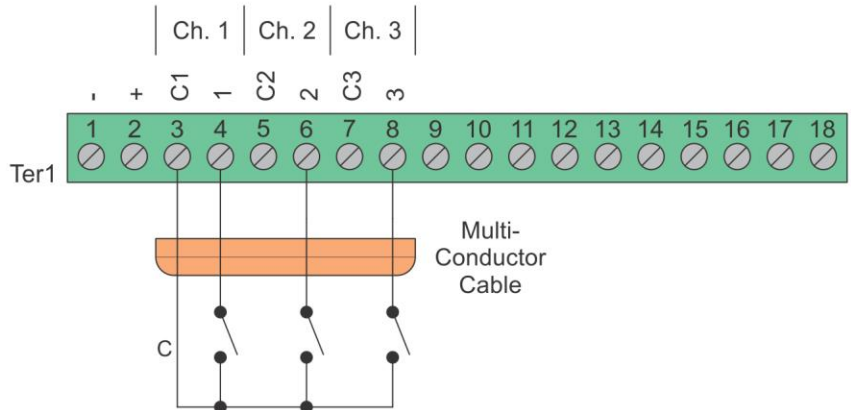

SPDT Switches

The common (C) terminal of the switch only needs to be connected to one of the channels ground terminal. In this configuration one channel would be transmitting all the time. A switch with a center "off" position would allow transmitting to stop.

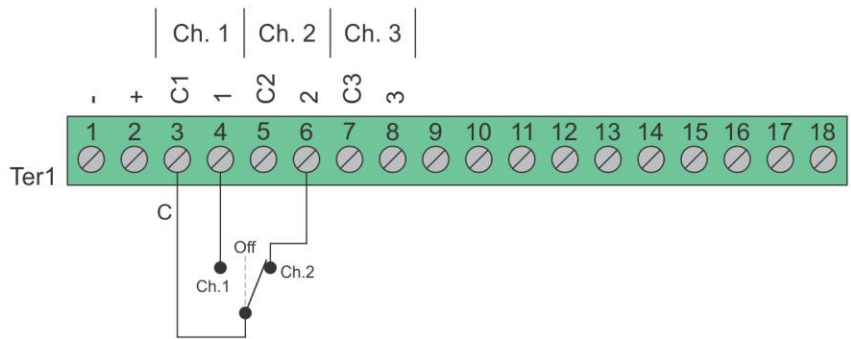

Wiring configurations shown here are examples. The wiring for your application may differ.
Call BWI Eagle for assistance or consult an electrician.