



105 Bonnie Drive
Butler, PA 16002
724-283-4681
724-283-5939 (fax)
www.bwieagle.com

PRODUCT INFORMATION BULLETIN

AIR-EAGLE® XLT PLUS High Power 900 MHz RF Transmitter DUAL CONTACT INPUT MODEL 461-1000-DC

DESCRIPTION

The AIR-EAGLE XLT PLUS TX is an R.F. transmitter capable of sending three dry-contact input commands to an Air-Eagle XLT PLUS Receiver located up to a mile away (*). Any number of transmitters and receivers can be combined to create a long range radio frequency system that operates hazardous or hard-to-reach electrical apparatus from safe, convenient locations. Seven user-selectable frequencies allow multiple systems to operate simultaneously in the same area without interference.

(*)- Longer distances can be achieved by using external antennas)

INSTALLATION

1. Mount the AIR-EAGLE XLT PLUS TRANSMITTER in a convenient location.
2. Install transmit control wiring to contact input terminal strip.
3. Attach rubber duck antenna or coax from external antenna to connector on side of enclosure.
4. Connect DC power to the proper terminals in your control circuit.

PC BOARD SET-UP INFORMATION

Make the following connections on the PC Board Terminal Strip (TER1)

TERMINAL STRIP WIRING (TER1)	
Terminal 1	Negative (-) 9-36VDC INPUT
Terminal 2	Positive (+) 9-36VDC INPUT
Terminal 3	CH1 Dry Contact Input (Common)
Terminal 4	CH1 Dry Contact Input
Terminal 5	CH2 Dry Contact Input (Common)
Terminal 6	CH2 Dry Contact Input
Terminal 7	CH3 Dry Contact Input (Common)
Terminal 8	CH3 Dry Contact Input
Terminal 9	Not Used
Terminal 10	Not Used
Terminal 11	Not Used
Terminal 12	Not Used
Terminal 13	Not Used
Terminal 14	Not Used
Terminal 15	Not Used
Terminal 16	Not Used
Terminal 17	Not Used
Terminal 18	Not Used



CONTROLS & INDICATORS

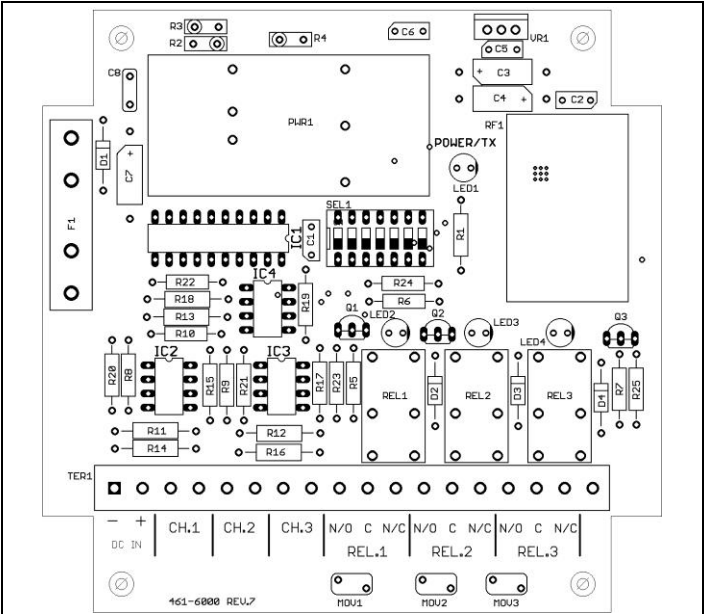

PWR/TX LED	Illuminates Green when power is applied, changes to Red when transmitting.
LED 1, 2 & 3	Not used on this model
CH1 – CH3 Dry Contact Inputs	Transmit individual RF codes to the remote receiver
REL1, REL2, REL3	Not used on this model
RF1	RF Module that transmits/receives data

AIR-EAGLE® XLT PLUS

High Power 900 MHz RF Transmitter
DUAL CONTACT INPUT

MODEL 461-1000-DC

GENERAL OPERATION

A contact closure on each input transmits to energize the corresponding relay in any receiver within transmit range. The signal transmits continuously as long as the input is closed.

FREQUENCY SET-UP

The unit is shipped from the factory with all SEL1 switches in the open positions. By default, it is operating on Frequency #1. If you wish to change the frequency, follow the instructions on the table below.

- 1) Remove power from unit
- 2) Remove top cover.
- 3) Select desired network frequency using table below.
- 4) Reattach cover and apply power.
- 5) Programming is now complete.

SEL 1 (SW 1-3): <i>(NETWORK FREQUENCY)</i>	Network Address	SW1	SW2	SW3
	1 (default)	OPEN	OPEN	OPEN
	2	CLOSED	OPEN	OPEN
	3	OPEN	CLOSED	OPEN
	4	CLOSED	CLOSED	OPEN
	5	OPEN	OPEN	CLOSED
	6	CLOSED	OPEN	CLOSED
	7	OPEN	CLOSED	CLOSED
SEL 1 (SW4-7)	Reserved for future use			

DIMENSIONS

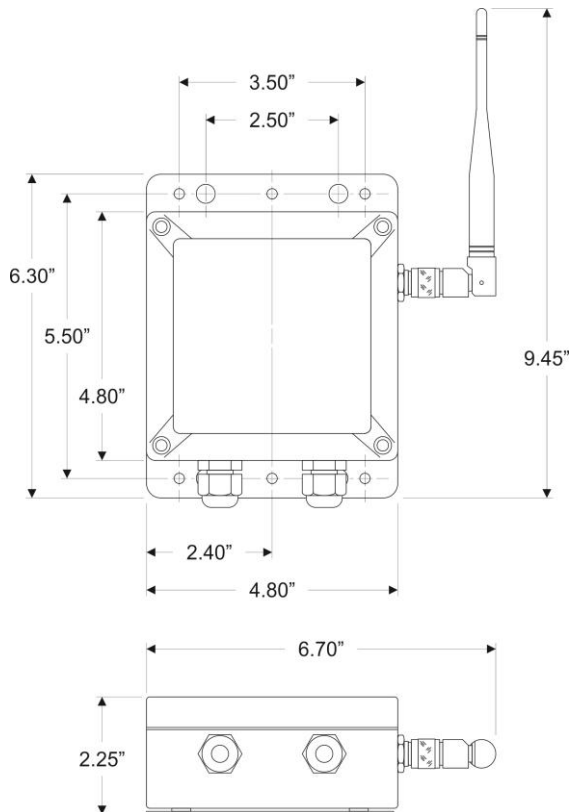

SPECIFICATIONS

Power Supply	9-36 VDC, 16 W, 50/60 Hz
Fuse Protected	2 amp
Transmitter Data	Three DRY Contact Inputs
Transmit Frequency	900MHz Spread Spectrum
RF Channels	Seven independent network frequencies
RF Output Power	1 Watt
Transmit Range	Approximately 1 Mile with Rubber Duck Antenna / Up to 10 Miles with External High Gain Antenna
Enclosure	Polycarbonate, IP66 (NEMA 4)
Operating Temp	-40° F - +185° F

APPROVALS

United States (FCC)	MCQ-XBPSX
Canada (IC)	1846A-XBPSX

REPLACEMENT PARTS & ACCESSORIES

PC Board (Main)	461-1002
Standard Antenna (Included):	
900MHz Portable Antenna (For distances up to 1 mile)	49-1103
Optional Antennas and Accessories:	
900MHz Omni Directional Antenna (For distances up to 5 miles*)	49-3101
900MHz 13dB Yagi Antenna Long Range Operation (For distances up to 10 miles*)	49-3102
Flex Coax Cable w/Connectors	49-4000-XX (XX = # of Feet)
* = Line of Sight	

LIMITED WARRANTY STATEMENT

BWI Eagle Inc. warrants the Air-Eagle Remote Control System, if properly used and installed, will be free from defects in material and workmanship for a period of **1 year** after date of purchase. Said warranty to include the repair or replacement of defective equipment. This warranty does not cover damage due to external causes, including accident, problems with electrical power, usage not in accordance with product instructions, misuse, neglect, alteration, repair, improper installation, or improper testing. This limited warranty, and any implied warranties that may exist under state law, apply only to the original purchaser of the equipment, and last only for as long as such purchaser continues to own the equipment. This warranty replaces all other warranties, express or implied including, but not limited to, the implied warranties or merchantability and fitness for a particular purpose. BWI Eagle makes no express warranties beyond those stated here. BWI disclaims without limitation, implied warranties of merchantability and fitness for a particular purpose. Some jurisdictions do not allow the exclusion of implied warranties so this limitation may not apply to you. To obtain warranty service, contact BWI Eagle for a return material authorization. When returning equipment to BWI Eagle, the customer assumes the risk of damage or loss during shipping and is responsible for the shipping costs incurred.

DOCUMENT DATE: 3/2/18 / PRODUCT REV.7