



105 Bonnie Drive
Butler, PA 16002
724-283-4681
724-283-5939 (fax)
www.bwieagle.com

PRODUCT INFORMATION BULLETIN

AIR-EAGLE® XLT 900 MHz RF Transceiver MODEL 441-40100-AC

DESCRIPTION

The AIR-EAGLE XLT RF TRANSCEIVER IS a single I/O unit designed to transmit and receive unique signals from another transceiver located up to 2500 feet away. This model comes equipped with a single contact input and a 5amp SPDT relay output. This allows the user to not only transmit information out, but receive a confirming signal back that the operation was performed. The Air-Eagle XLT TRX is user-programmable for up to seven network frequencies to allow multiple systems to operate simultaneously in the same area and utilizes spread-spectrum technology and provides the utmost security and reliability even in the noisiest RF environments. A terminal strip has been provided for interfacing with external dry contact inputs as well as dry contact relay outputs. This unit can operate remote machinery such as pumps, gates, chutes etc.

APPROVALS

United States (FCC)	MCQ-XB900HP
Canada (IC)	1846A-XB900HP

APPLICATIONS

Doors, gates, barriers, tail gates, electrically controlled hydraulic valves, propane shut off controls, winches, anchor lifts, lights, sprinkling systems, movie screens, curtains, news weather screens, alarm systems, skeet throwers, saw mill applications, grain or aggregate chutes, conveyor belts, boat lifts, and more.

INSTALLATION

DISCONNECT AC Power from all equipment before installation.

1. Mount the AIR-EAGLE XLT TRANSCEIVER in a convenient location.
2. Install wiring to terminal strip
3. Install antenna onto connector located on the right side on the enclosure.
4. Connect AC power to the proper terminals in your control circuit.

TERMINAL STRIP WIRING

TER 3 DRY CONTACT INPUT		TER 2 RELAY OUTPUT		TER 1 AC/DC POWER INPUT	
1	Input 1 C	1	N/O	1	120VAC (Neutral)
2	Input 1	2	C (common)	2	120VAC (Hot)
		3	N/C	3	Ground



Dimensions (with mounting plate) 7.07L x 3.57W x 1.62H

CONTROLS AND INDICATORS

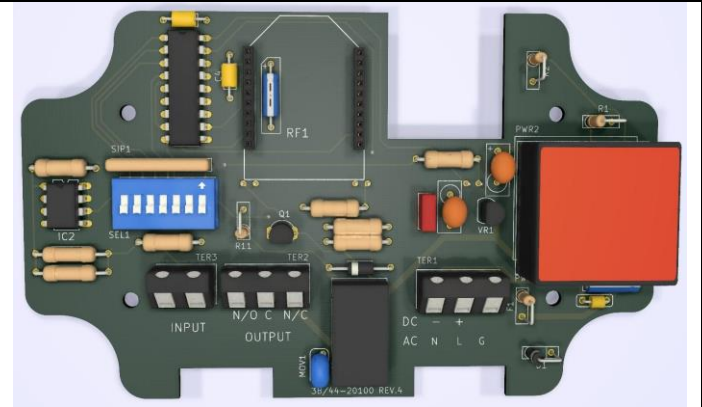

Power – LED1	Illuminates green when unit is powered
TX – LED2	Illuminates red when unit is transmitting
Relay – LED3	Illuminates green when relay is energized
RF1	RF module that sends data to the remote receiver
SEL1	Seven dip switches for selecting options and network frequency
TER3	Dry contact input
TER2	Relay output
TER1	Power Input

AIR-EAGLE® XLT

900 MHz RF Transceiver

MODEL 441-40100-AC

RELAY & FREQUENCY SET-UP

The unit is shipped from the factory with SEL1 switches in the open positions. The relay will operate as maintained momentary and unit is receiving commands on frequency one. If you wish to change these default settings, follow the instructions on the table below.

- 1) Remove power from unit
- 2) Remove top cover.
- 3) Select desired relay operation and/or network frequency using table below.
- 4) Reattach cover and apply power.
- 5) Programming is now complete.

RELAY CONFIGURATION

	Relay Operation	SW1	SW1
SEL1 (SW1-2)	Momentary (default)	OPEN	OPEN
	Toggle/Latch	CLOSED	OPEN
	Latching	OPEN	CLOSED

OPTIONS

SW3	Vibrating Feedback Off	Vibrating Feedback On
SW4**	Repeater Function Off (default)	Repeater Function On

Maintained Momentary – Relay mimics button or input – when depressed or closed, relay will be energized; when released, relay de-energizes

Toggle/Latch – Relay changes (and holds) its state each time the corresponding button or input is depressed or closed.

Latching – Relay requires two buttons or inputs for operation – momentary press of 1st button energizes relay; momentary press of 2nd button de-energizes relay

** Enable SW4 Repeater Function in ONLY one Receiver per System

FREQUENCY SET-UP

	Network Frequency	SW5	SW6	SW7
SEL1 (SW5-7)	1 (default)	OPEN	OPEN	OPEN
	2	CLOSED	OPEN	OPEN
	3	OPEN	CLOSED	OPEN
	4	CLOSED	CLOSED	OPEN
	5	OPEN	OPEN	CLOSED
	6	CLOSED	OPEN	CLOSED
	7	OPEN	CLOSED	CLOSED

SPECIFICATIONS

AC Input	110-240 VAC, 5 W, 50/60 Hz
RF Output Power	250 mW
Transmit Data	Dry Contact Input
Relay Contact	SPDT 5 amp @ 120VAC or 30VDC per channel
Fuse Protected	1 amp
Receiver Range	Up to 2500 Ft. with Standard Antenna – Up to 4 Miles with External High Gain Antenna
Receiver Frequency	900 MHz Spread Spectrum
Receiver Channels	Seven independent network frequencies
Operating Temperature	-40° F to +185° F
Enclosure	Polycarbonate NEMA 4, 12, 13 – IP66
Weight	Approx 2 lbs.

DIMENSIONS

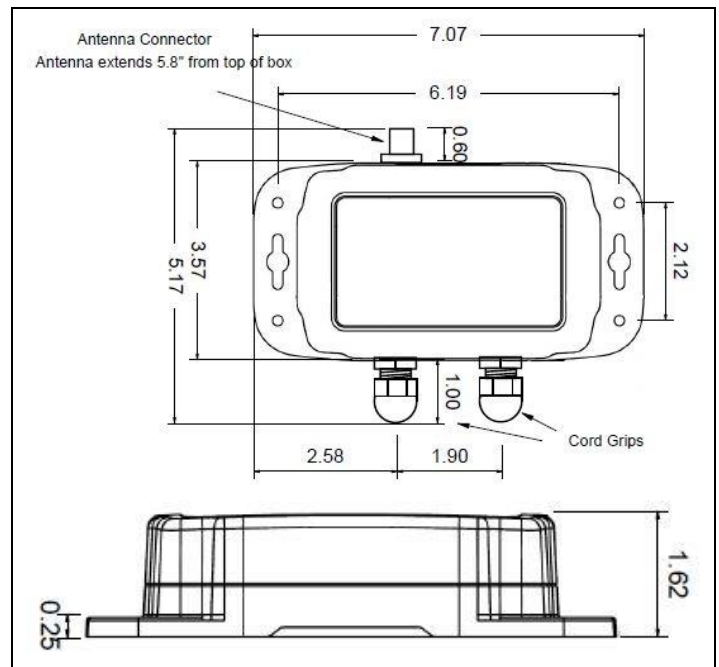

REPLACEMENT PARTS & ACCESSORIES

PC Board (Main)	441-40102-AC
Standard Antenna (Included):	
900MHz Portable Antenna (For distances up to 2500 feet*)	49-1103
Optional Antennas and Accessories – Used to increase range in both non line of sight and line of sight applications. - Contact BWI Eagle for recommendations	
900MHz Omni Directional Antenna (For distances up to 2 miles*)	49-3101
900MHz 13dB Yagi Antenna Long Range Operation (For distances up to 4 miles*)	49-3102
Flex Coax Cable w/Connectors	49-4000-XX (XX = # of Feet)
2 Ft. Bulkhead Assembly (Used when mounting receiver inside another enclosure)	49-5004-2-ISO

AIR-EAGLE® XLT

900 MHz RF Transceiver

MODEL 441-40100-AC

LIMITED WARRANTY STATEMENT

BWI Eagle Inc. warrants the Air-Eagle Remote Control System, if properly used and installed, will be free from defects in material and workmanship for a period of 1 year after date of purchase. Said warranty to include the repair or replacement of defective equipment. This warranty does not cover damage due to external causes, including accident, problems with electrical power, usage not in accordance with product instructions, misuse, neglect, alteration, repair, improper installation, or improper testing. This limited warranty, and any implied warranties that may exist under state law, apply only to the original purchaser of the equipment, and last only for as long as such purchaser continues to own the equipment. This warranty replaces all other warranties, express or implied including, but not limited to, the implied warranties of merchantability and fitness for a particular purpose. BWI Eagle makes no express warranties beyond those stated here. BWI disclaims without limitation, implied warranties of merchantability and fitness for a particular purpose. Some jurisdictions do not allow the exclusion of implied warranties so this limitation may not apply to you. To obtain warranty service, contact BWI Eagle for a return material authorization. When returning equipment to BWI Eagle, the customer assumes the risk of damage or loss during shipping and is responsible for the shipping costs incurred.

DOCUMENT DATE: 08/27/19 / PRODUCT REV. 5



105 Bonnie Drive
Butler, PA 16002
(724) 283-4681
Fax (724) 283-5939
www.bwieagle.com



105 Bonnie Drive
Butler, PA 16002
724-283-4681
724-283-5939 (fax)
www.bwieagle.com

INPUT/OUTPUT WIRING

1-Input Transmitter / 1-Relay Receiver

Dry Contact Input Wiring - Standard

Standard wiring of a dry contact input transmitter

Shorting together the contacts of the respective channel will cause it to transmit. This can be done with any type of manual or automatic switch.

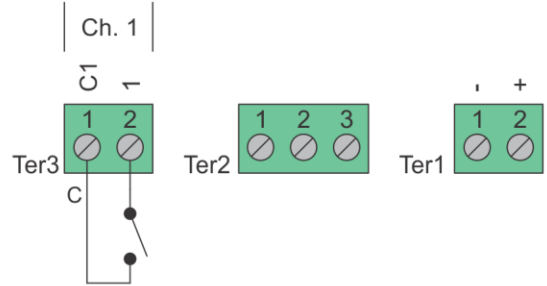

Relay Output Wiring

Receiver outputs are dry relay contacts, like an SPDT switch. When the relay is in a de-energized state, the N/C (normally closed) contact is connected to C (common). When the relay is energized the N/O (normally open) contact is connected to C (common).

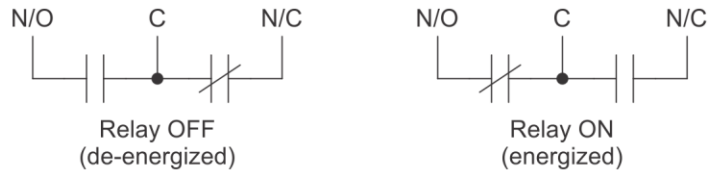

Relay Output Wiring - Normally Open Application with Externally Supplied Voltage

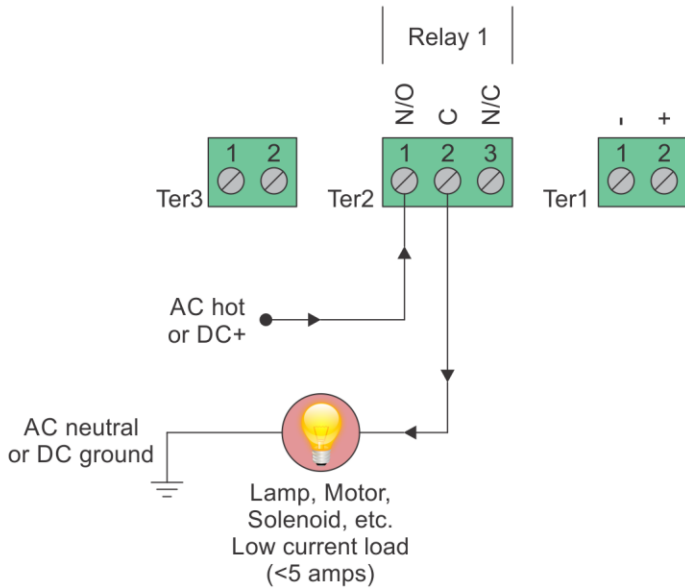

Internal Relay - Loads Less Than 5 Amps

Loads up to 5 Amps may be wired directly to the internal relays. Wiring to the N/O contact will cause the load to turn on when the relay is energized (the load is on when the relay is on). Wiring to the N/C contact will cause the load to turn on when the relay is de-energized (the load is on when the relay is off). AC or DC voltages can be switched through the relay.

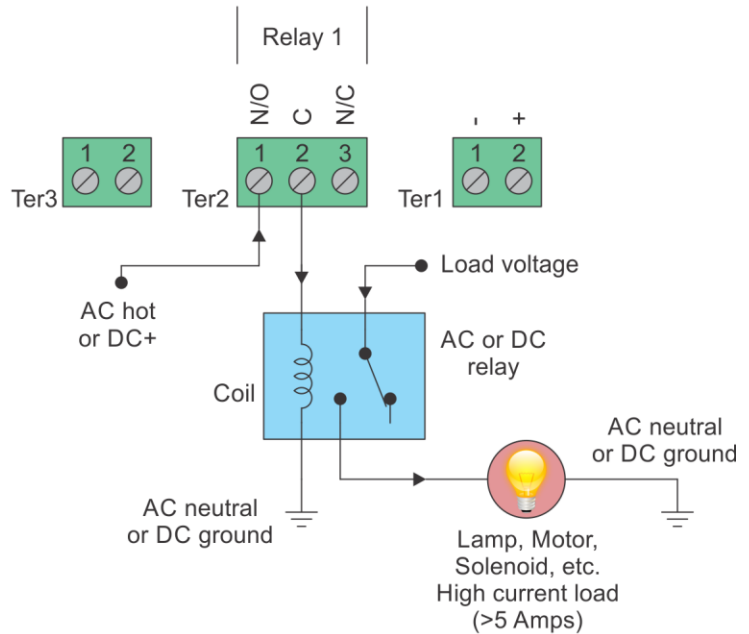

External Relay - Loads Over 5 Amps

Loads over 5 Amps must use an external high current relay. Diagram shows how to turn on the relay using the lower current internal relay of the receiver. AC or DC voltages can be switched through the relay. Note: A protection diode for DC coils or an MOV for AC coils is recommended to reduce inductive EMI noise.

Wiring configurations shown here are examples. The wiring for your application may differ.
Call BWI Eagle for assistance or consult an electrician.