



105 Bonnie Drive  
Butler, PA 16002  
724-283-4681  
724-283-5939 (fax)  
www.bwieagle.com

# PRODUCT INFORMATION BULLETIN

## AIR-EAGLE® XLT 900 MHz RF Receiver MODEL 441-20100-AC

### DESCRIPTION

The AIR-EAGLE XLT is an RF system designed for short to medium range wireless remote control of electrical apparatus in a variety of industrial applications. Systems can consist of any number of receivers and handheld or contact input transmitters working together. This receiver is equipped with single relay can switch 5 amps @ 120VAC or 30VDC. The relay is user programmable for momentary, toggle/latching or latching operation and can be directly interfaced with the customer's equipment or P.L.C. Seven user selectable frequencies allow multiple systems to be used in the same area. Capable of receiving remote signals transmitted from up to 2500 feet away (with the handheld transmitter) or up to 2 miles away (with the contact input transmitter), the Air-Eagle XLT utilizes spread-spectrum technology and provides the utmost security and reliability even in the noisiest RF environments.

### SERIES FEATURE

The "441" Series features repeating capability. Transmitters can be set up to send "repeat signal packets", and any transmitter or receiver within its range will repeat the signal packet to help propagate communication over widespread areas.

### APPROVALS

United States (FCC)	MCQ-XB900HP
Canada (IC)	1846A-XB900HP

### INSTALLATION

DISCONNECT AC Power from all equipment before installation.

1. Mount the AIR-EAGLE XLT RECEIVER in a convenient location.
2. Install wiring to terminal strip.
3. Attach supplied rubber duck antenna to TNC connector on the top side of the unit.
4. Connect AC power to the proper terminals in your control circuit.

### TERMINAL STRIP WIRING

TER 3 INPUT		TER 2 RELAY OUTPUT		TER 1 AC/DC POWER INPUT	
1	Not Used	1	N/O	1	120VAC (Neutral)
2	Not Used	2	C (common)	2	120VAC (Hot)
		3	N/C	3	Ground



Dimensions (with mounting plate)  
7.07L x 3.57W x 1.62H

### CONTROLS AND INDICATORS

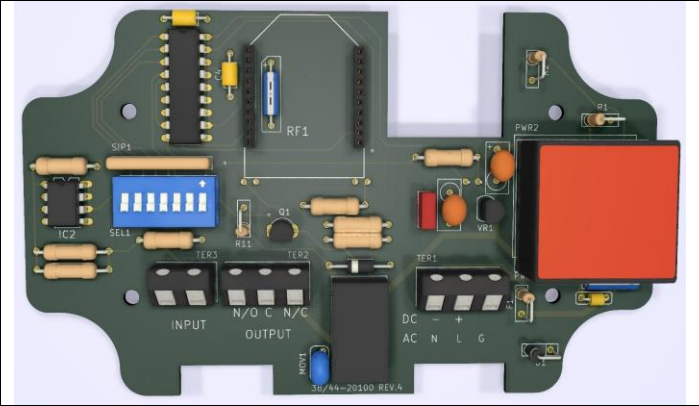

Power – LED1	Illuminates green when unit is powered
TX – LED2	Not used on this model
Relay – LED3	Illuminates green when relay is energized
RF1	RF module that sends data to the remote receiver
SEL1	Seven dip switches for selecting options & network frequency
TER3	Dry contact input
TER2	Relay output
TER1	Power Input

# AIR-EAGLE® XLT

900 MHz RF Receiver

**MODEL 441-20100-AC**

## RELAY & FREQUENCY SET-UP

The unit is shipped from the factory with SEL1 switches in the open positions. The relay will operate as maintained momentary and unit is receiving commands on frequency one. If you wish to change these default settings, follow the instructions on the table below.

- 1) Remove power from unit
- 2) Remove top cover.
- 3) Select desired relay operation and/or network frequency using table below.
- 4) Reattach cover and apply power.
- 5) Programming is now complete.

### RELAY CONFIGURATION

SEL1 (SW1-2)	Relay Operation	SW1	SW2
	Momentary (default)	OPEN	OPEN
	Toggle/Latch	CLOSED	OPEN
	Latching	OPEN	CLOSED

### OPTIONS

SW3	Vibrating Feedback Off	Vibrating Feedback On
SW4**	Repeater Function Off (default)	Repeater Function On

**Maintained Momentary** – Relay mimics button or input – when depressed or closed, relay will be energized; when released, relay de-energizes

**Toggle/Latch** – Relay changes (and holds) its state each time the corresponding button or input is depressed or closed.

**Latching** – Relay requires two buttons or inputs for operation – momentary press of 1<sup>st</sup> button energizes relay; momentary press of 2<sup>nd</sup> button de-energizes relay

\*\* Enable SW4 Repeater Function in ONLY one Receiver per System

### FREQUENCY SET-UP

SEL1 (SW5-7)	Network Frequency	SW5	SW6	SW7
	1 (default)	OPEN	OPEN	OPEN
	2	CLOSED	OPEN	OPEN
	3	OPEN	CLOSED	OPEN
	4	CLOSED	CLOSED	OPEN
	5	OPEN	OPEN	CLOSED
	6	CLOSED	OPEN	CLOSED
	7	OPEN	CLOSED	CLOSED

## SPECIFICATIONS

AC Input	110-240 VAC, 5 W, 50/60 Hz
Relay Contact	SPDT 5 amp @ 120VAC or 30VDC
Fuse Protected	1 amp
Receiver Frequency	900 MHz Spread Spectrum
Receiver Range – Dependent upon transmitter – see below:	
Using Handheld TX	Approximately 2500 feet
Using Stationary TX & External Antenna	Up to 2 Miles
Receiver Channels	Seven independent network frequencies
Operating Temperature	-40° F to +185° F
Enclosure	Polycarbonate NEMA 4, 12, 13 – IP66
Weight	Approx 2 lbs.

## DIMENSIONS

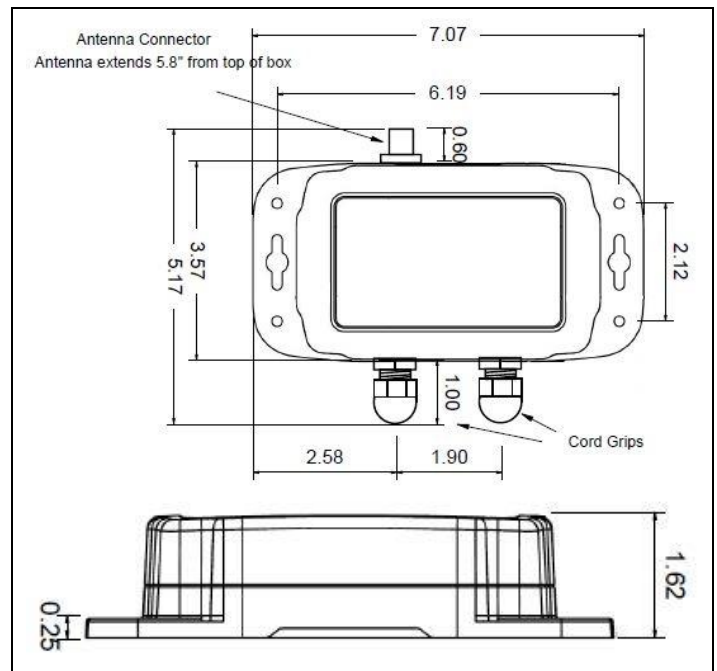

## REPLACEMENT PARTS & ACCESSORIES

PC Board (Main)	441-20102-AC
Standard Antenna (Included):	
900MHz Portable Antenna (For distances up to 2500 feet*)	49-1103
Optional Antennas and Accessories – Used to increase range in both non line of sight and line of sight applications. - Contact BWI Eagle for recommendations	
900MHz Omni Directional Antenna (For distances up to 2 miles*)	49-3101
900MHz 13dB Yagi Antenna Long Range Operation (For distances up to 4 miles*)	49-3102
Flex Coax Cable w/Connectors	49-4000-XX (XX = # of Feet)
2 Ft. Bulkhead Assembly (Used when mounting receiver inside another enclosure)	49-5004-2

**AIR-EAGLE® XLT**

**900 MHz RF Receiver**

**MODEL 441-20100-AC**

## LIMITED WARRANTY STATEMENT

BWI Eagle Inc. warrants the Air-Eagle Remote Control System, if properly used and installed, will be free from defects in material and workmanship for a period of 1 year after date of purchase. Said warranty to include the repair or replacement of defective equipment. This warranty does not cover damage due to external causes, including accident, problems with electrical power, usage not in accordance with product instructions, misuse, neglect, alteration, repair, improper installation, or improper testing. This limited warranty, and any implied warranties that may exist under state law, apply only to the original purchaser of the equipment, and last only for as long as such purchaser continues to own the equipment. This warranty replaces all other warranties, express or implied including, but not limited to, the implied warranties of merchantability and fitness for a particular purpose. BWI Eagle makes no express warranties beyond those stated here. BWI disclaims without limitation, implied warranties of merchantability and fitness for a particular purpose. Some jurisdictions do not allow the exclusion of implied warranties so this limitation may not apply to you. To obtain warranty service, contact BWI Eagle for a return material authorization. When returning equipment to BWI Eagle, the customer assumes the risk of damage or loss during shipping and is responsible for the shipping costs incurred.

---

DOCUMENT DATE: 12/11/2019 / PRODUCT REV. 5

---



105 Bonnie Drive  
Butler, PA 16002  
(724) 283-4681  
Fax (724) 283-5939  
[www.bwieagle.com](http://www.bwieagle.com)



105 Bonnie Drive  
Butler, PA 16002  
724-283-4681  
724-283-5939 (fax)  
www.bwieagle.com

# INPUT/OUTPUT WIRING

## 1-Input Transmitter / 1-Relay Receiver

### Dry Contact Input Wiring - Standard

**Standard wiring of a dry contact input transmitter**

Shorting together the contacts of the respective channel will cause it to transmit. This can be done with any type of manual or automatic switch.

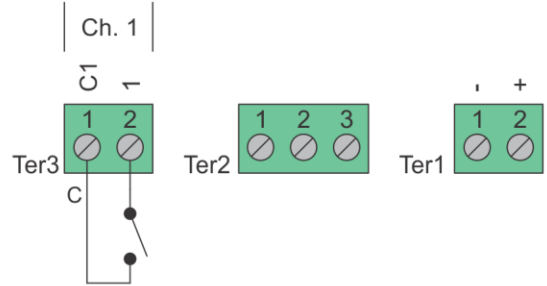

### Relay Output Wiring

Receiver outputs are dry relay contacts, like an SPDT switch. When the relay is in a de-energized state, the N/C (normally closed) contact is connected to C (common). When the relay is energized the N/O (normally open) contact is connected to C (common).

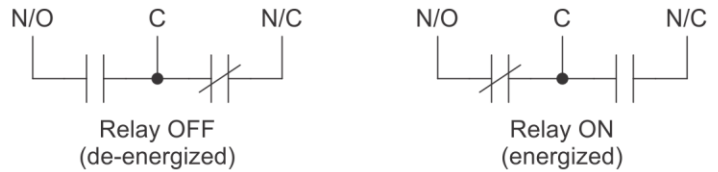

### Relay Output Wiring - Normally Open Application with Externally Supplied Voltage

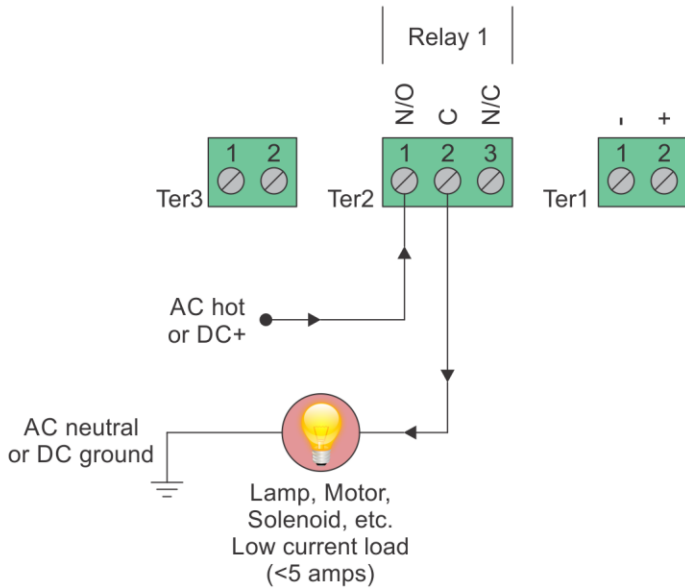

**Internal Relay - Loads Less Than 5 Amps**

Loads up to 5 Amps may be wired directly to the internal relays. Wiring to the N/O contact will cause the load to turn on when the relay is energized (the load is on when the relay is on). Wiring to the N/C contact will cause the load to turn on when the relay is de-energized (the load is on when the relay is off). AC or DC voltages can be switched through the relay.

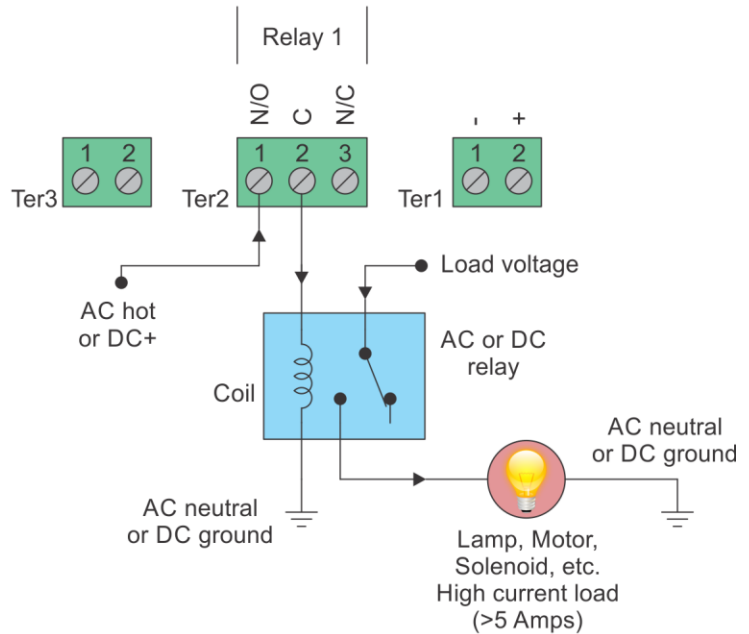

**External Relay - Loads Over 5 Amps**

Loads over 5 Amps must use an external high current relay. Diagram shows how to turn on the relay using the lower current internal relay of the receiver. AC or DC voltages can be switched through the relay. Note: A protection diode for DC coils or an MOV for AC coils is recommended to reduce inductive EMI noise.

Wiring configurations shown here are examples. The wiring for your application may differ.  
Call BWI Eagle for assistance or consult an electrician.